



Owner's Manual and Instructions

Tradesman Kerosene Heaters



MODELS	OUTPUT (BTUH)	FUEL
CP400DK	400,000	1-K Kerosene
CP650DK	650,000	

Certification by:



SCAN THIS QR CODE

with your smartphone or visit <http://goo.gl/nvneR> to view maintenance videos for L.B.White heaters.*



*Requires an app like QR Droid for Android or QR Reader for iPhone.

Congratulations!

You have purchased the finest kerosene portable forced air construction heater available.

Your new L.B. White heater incorporates the benefits from the most experienced manufacturer of heating products using state-of-the-art technology.

We, at L.B. White, **thank you** for your confidence in our products and welcome any suggestions or comments you may have...call us, toll-free, at (800) 345-7200 or e-mail customerservice@lbwhite.com

ATTENTION ALL USERS

This heater has been tested and evaluated by C.S.A. International in accordance with the requirements of Standard ANSI A10.10-1998, CAN/CSA B140.0-03 and CSA B140.8 - 1967 and is listed and approved as a Kerosene forced-air construction heater with application for the temporary heating of buildings under construction, alteration, or repair. If you are considering using this product for any application other than its intended use, then please contact the L.B. White Co., Inc.



Quality heaters you can count on.

411 Mason St., Onalaska, WI 54650 ■ (800) 345-7200 ■ (608) 783-5691 ■ (608) 783-6115, fax ■ info@lbwhite.com

 **GENERAL HAZARD WARNING**

- Failure to comply with the precautions and instructions provided with this heater, can result in:
 - Death
 - Serious bodily injury or burns
 - Property damage or loss from fire or explosion
 - Asphyxiation due to lack of adequate air supply or carbon monoxide poisoning
 - Electrical shock
- Read this Owner's Manual before installing or using this product.
- Only properly-trained service people should repair or install this heater.
- Save this Owner's Manual for future use and reference.
- Owner's Manuals and replacement labels are available at no charge. See website, or for assistance, contact L.B. White at 800-345-7200.

 **WARNING**

Fire and Explosion Hazard

- Not for home or recreational vehicle use.
- Installation of this heater in a home or recreational vehicle may result in a fire or explosion.
- Fire or explosions can cause property damage or loss of life.

FOR YOUR SAFETY

Do not store or use gasoline or other flammable vapors and liquids in the vicinity of this or any other appliance.

 **WARNING**

Fire and Explosion Hazard

- Keep solid combustibles a safe distance away from the heater.
- Solid combustibles include wood, paper, or plastic products, building materials and dust.
- Do not use the heater in spaces which contain or may contain volatile or airborne combustibles.
- Volatile or airborne combustibles include gasoline, solvents, paint thinner, dust particles or unknown chemicals.
- Failure to follow these instructions may result in a fire or explosion.
- Fire or explosions can lead to property damage, personal injury or loss of life.



Table of Contents

<u>SECTION</u>	<u>PAGE</u>
General Information	3
Heater Specifications	4
Information	
Hazard Definitions	5
General Safety Information	5
Installation & Assembly	
Heater Specifications	7
Assembly	7
Operation	
Overview of Heater Design	11
The Safety System	11
Fuel Specifications	11
Fueling Your Heater	12
To Start Heater	12
To Shutdown Heater	12
To Restart Heater	12
Extra Electrical Outlet	13
Longterm Storage of Your Heater	13
Maintenance	
Fan Blade and Air Deflector	14
Nozzle	15
Spark Plug	15
Photocell	16
Fuel Lines	16
Fuel Filter	16
Pump Pressure Adjustment	17
Replacing Fuse	18
Wiring Diagram	18
Troubleshooting	19
Parts Identification	
Parts Schematic CP400DK	20
Parts List CP400DK	21
Parts Schematic CP650DK	22
Parts List CP650DK	23
Parts Schematic Burner Head CP400DK,CP650DK	24
Parts Schematic Burner Assembly CP400DK, CP650DK	25
Parts Schematic Handle and Wheels CP400DK	26
Parts Schematic handle and Wheels CP650DK	27
Warranty Information	28

General Information

This Owner's Manual includes all options and accessories commonly used on this heater.

When calling for technical service assistance, or for other specific information, always have model number, configuration number and serial number available. This information is contained on the dataplate.

This manual will instruct you in the operation and care of your unit. Have your qualified installer review this manual with you so that you fully understand the heater and how it functions.

The installation, repair, and servicing of the heater requires continuing expert training and knowledge of kerosene heaters and should not be attempted by anyone who is not so qualified.

Contact your local L.B. White distributor or the L.B. White Co., Inc. for assistance, or if you have any questions about the use of the equipment or its application.

The L.B. White Co., Inc. has a policy of continuous product improvement. It reserves the right to change specifications and design without notice.

Heater Specifications

		Model	
SPECIFICATIONS		CP400DK	CP650DK
Fuel Type		1-K, Kerosene	
Max Input (BTUH)		400,000	650,000
Pump Pressure (psig)		125	110
Fuel Consumption per Hour (gal)		3.0	4.9
Motor Characteristics		Ball Bearing	
		1/2 HP, 1710 RPM	3/4 HP, 1680 RPM
Electrical Supply (Volt/Hz/Phase)		120/60/1	
Amp Draw	CONTINUOUS OPERATION	4.4	7.1
Dimensions (Inches) Length x width x height		52.5" x 31.4" x 32.8"	69.2" x 32.8" x 48.7"
Minimum Safe Distances From Nearest Combustible Materials	TOP	4 ft.	
	SIDES	4 ft.	
	BACK	4 ft.	
	BLOWER OUTLET	8 ft.	
	BULK FUEL STORAGE CONTAINER	25 ft.	
Net Weight (Lbs.)		150	276
Shipping Weight (Lbs.)		163	298
Minimum Ambient Temperature in Which Heater May Be Used		-20°F	

Safety Information

HAZARD DEFINITIONS

 **DANGER**

Indicates an imminently hazardous situation which, if not avoided *WILL* result in death or serious injury.

 **WARNING**

Indicates a potentially hazardous situation which, if not avoided, *COULD* result in death or serious injury.

 **CAUTION**

Indicates a potentially hazardous situation which, if not avoided, *MAY* result in minor or moderate injury.

GENERAL SAFETY INFORMATION

 **WARNING**

Before using this heater, please read this USER'S MANUAL very carefully. This USER'S MANUAL has been designed to instruct you as to the proper manner in which to assemble, maintain, store, and most importantly, how to operate the heater in a safe and efficient manner.

 **WARNING**

Never leave the heater unattended while burning!

 **DANGER**

Improper use of this heater can result in serious injury or death from burns, fire, explosion, electrical shock, and/or carbon monoxide poisoning.

GENERAL SAFETY INFORMATION (cont.)

 **WARNING**
Risk of CO Poisoning!

- Use this heater only in well ventilated areas. Provide proper ventilation. Proper ventilation air for combustion must be provided in accordance with OSHA 29 CFR 1926.154, Temporary Heating Devices, ANSI A 10.10, Safety Requirements for Temporary and Portable Space Heating Devices, or the Natural Gas and Propane Installation Code. CAN/CSA B149.1 as appropriate.
- Never use this heater in living or sleeping areas.
- Carbon Monoxide Poisoning: Early signs of carbon monoxide poisoning resemble flu-like symptoms such as headaches, dizziness, and/or nausea. If you have these symptoms, your heater may not be working properly.
- Get fresh air at once! Have the heater serviced.
- People with breathing problems should consult a physician before using the heater.
- Some people are more affected by carbon monoxide than others. These include pregnant women, those with heart or lung problems, anemia, or those under the influence of alcohol, or at high altitudes.

 **WARNING**
Risk of Electric Shock!

- Use only the electrical power (voltage and frequency) specified on the model plate of the heater. Use only a threeprong, grounded outlet and extension cord.
- ALWAYS install the heater so that it is not directly exposed to water spray, rain, dripping water, or wind.
- ALWAYS unplug the heater when not in use.

CALIFORNIA RESIDENTS: This heater produces carbon monoxide, which is listed by the State of California as a reproductive toxin under Proposition 65.

MASSACHUSETTS RESIDENTS: Massachusetts state law prohibits the use of this heater in any building which is used in whole or in part for human habitation. Use of this heating device in Massachusetts requires local fire dept. permit (M.E.L.C. 148, Section 10A).

CANADIAN RESIDENTS: Use of this heater shall be in accordance with authorities having jurisdiction and CSA Standard B139.

For CP400DK only.

NEW YORK CITY RESIDENTS: For use only at construction sites in accordance with applicable NYC codes under NYCFD certificate of approval #5037

 **WARNING**
Risk of Burns/Fire/Explosion!

- Keep all combustible materials away from this heater.
Minimum Clearances
Outlet 8 feet (250 cm)
Sides, Top and Rear 4 feet (125 cm)
- NEVER use fuels such as gasoline, benzene, paint thinners, or other oil compounds in this heater (RISK OF FIRE OR EXPLOSION).
- NEVER use this heater where flammable vapors may be present.
- NEVER refill the heater's fuel tank while heater is operating or still hot. This heater is EXTREMELY HOT while in operation.
- NEVER block air inlet (rear) or air outlet (front) of heater.
- NEVER use duct work in front or at rear of heater.
- NEVER move or handle heater while still hot.
- NEVER transport heater with fuel in its tank.
- The heater is equipped with a thermostat, the heater may start at any time.
- ALWAYS locate heater on a stable and level surface.
- Use 1-K kerosene in this heater. #1 fuel oil is a suitable substitute.
- Bulk fuel storage should be a minimum of 25 ft. from heaters, torches, portable generators, or other sources of ignition. All fuel storage should be in accordance with federal, state, or local authorities having jurisdiction.

Installation and Assembly Instructions

HEATER SPECIFICATIONS

Introduction

Please read this USER'S MANUAL carefully. It will show you how to assemble, maintain and operate this heater safely and efficiently to obtain the full benefits of its many features.

Consumer: Retain these instructions for future reference.

Unpacking

1. Remove all packing items applied to heater for shipment.
2. Remove all items from carton.
3. Check all items for shipping damage.
If heater is damaged, promptly inform dealer where you purchased heater.

DIMENSIONS & ASSEMBLY INSTRUCTIONS -CP400DK PRODUCT FEATURES

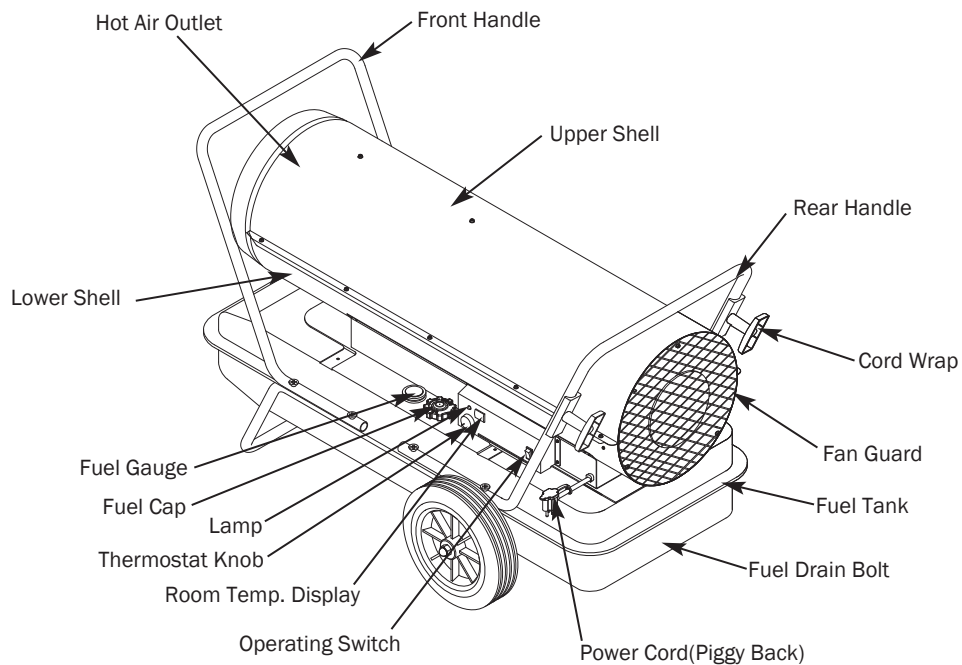
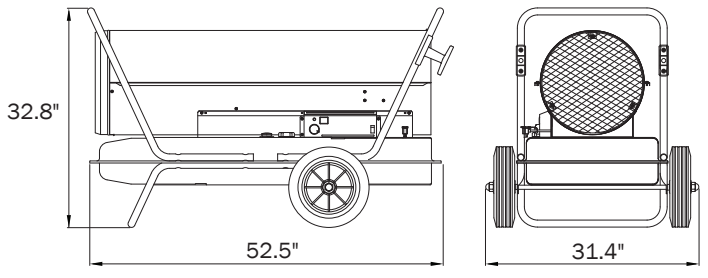

Figure 2 - Model CP400DK Features

DIMENSIONS & ASSEMBLY (cont.)

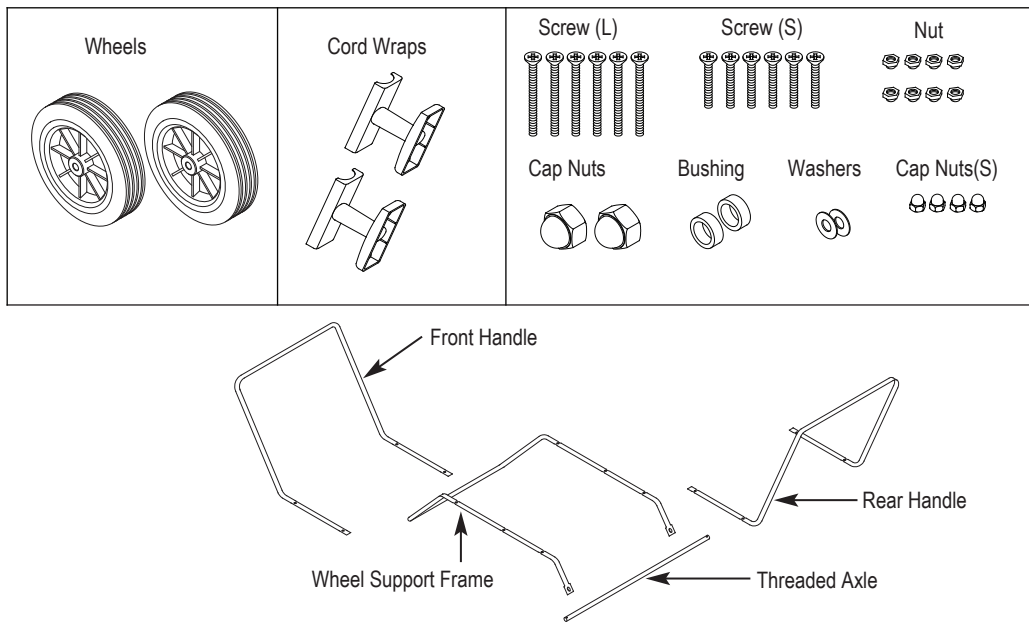

Figure 3 – Components

ASSEMBLY FOR CP400DK

TOOLS REQUIRED

- Medium Phillips screwdriver
- Adjustable wrench,

ASSEMBLING WHEEL & HANDLE

1. Slide threaded axle through the rear section of the wheel support frame.
2. Slide one axle bushing on to each side of the axle. Slide one wheel on to each side of the axle.
3. Attach one cap nut on to each side of the threaded axle and tighten well
4. Place heater on wheel support frame. Make sure air inlet end (rear) of heater is over wheels. Align the hole on fuel tank flange. Insert screws (L) through handles (front and Rear), fuel tank flange, and wheel support frame. Insert screws (S) through rear handle, fuel tank flange, and washer (S) as shown in figure 4 and attach nut finger tight after each screw is inserted.
5. After all screws are inserted, tighten nuts firmly.
6. Align the hole on the rear handle with the mounting hole on the cord wrap.
7. Insert screws through cord wrap, rear handle as shown in Figure 4 and attach nut finger tight after each screw is inserted.
8. After all screws are inserted, tighten nuts firmly.



CAUTION

Risk of fire or explosion
- Do not operate heater without support frame fully assembled to tank.

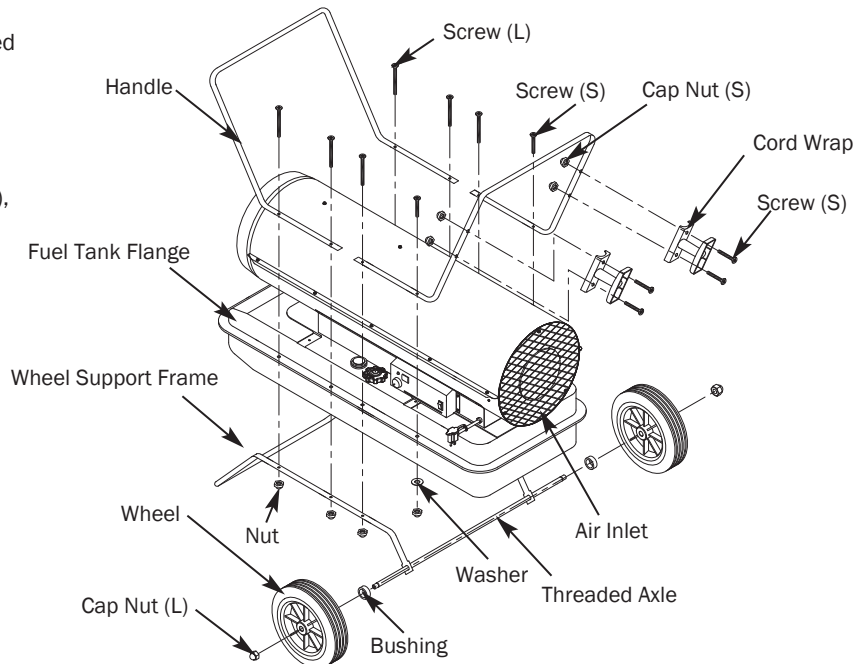

Figure 4 – Wheel and Handle Assembly

DIMENSIONS & ASSEMBLY (cont.)

DIMENSIONS ASSEMBLY INSTRUCTIONS - CP650DK PRODUCT FEATURES

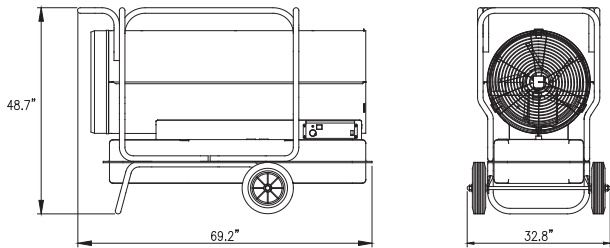

Figure 5 - Heater Dimensions

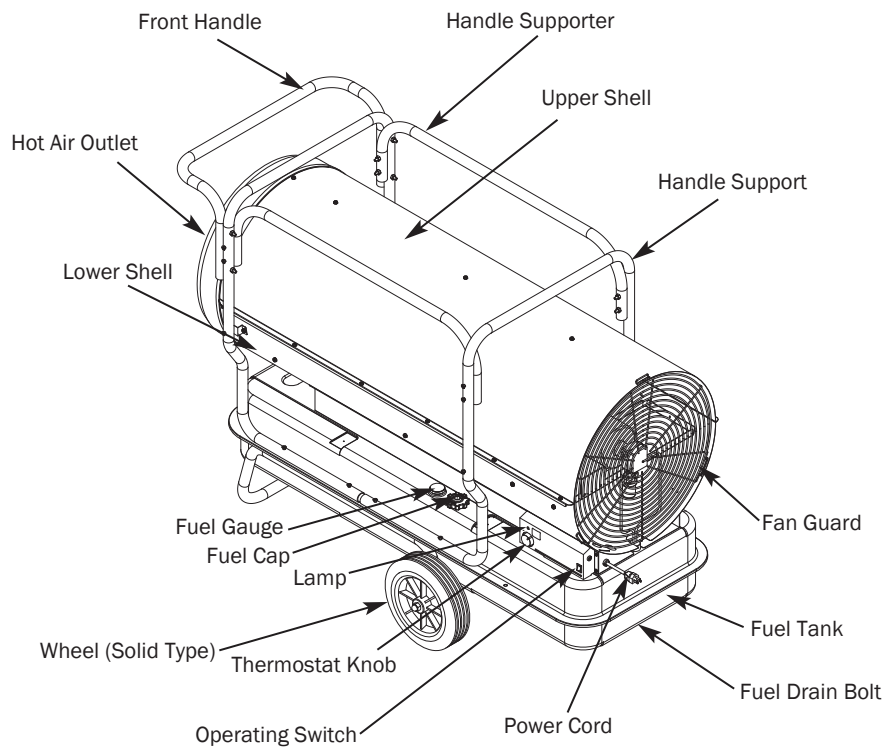

Figure 6 - Model CP650DK Features

DIMENSIONS & ASSEMBLY (cont.)

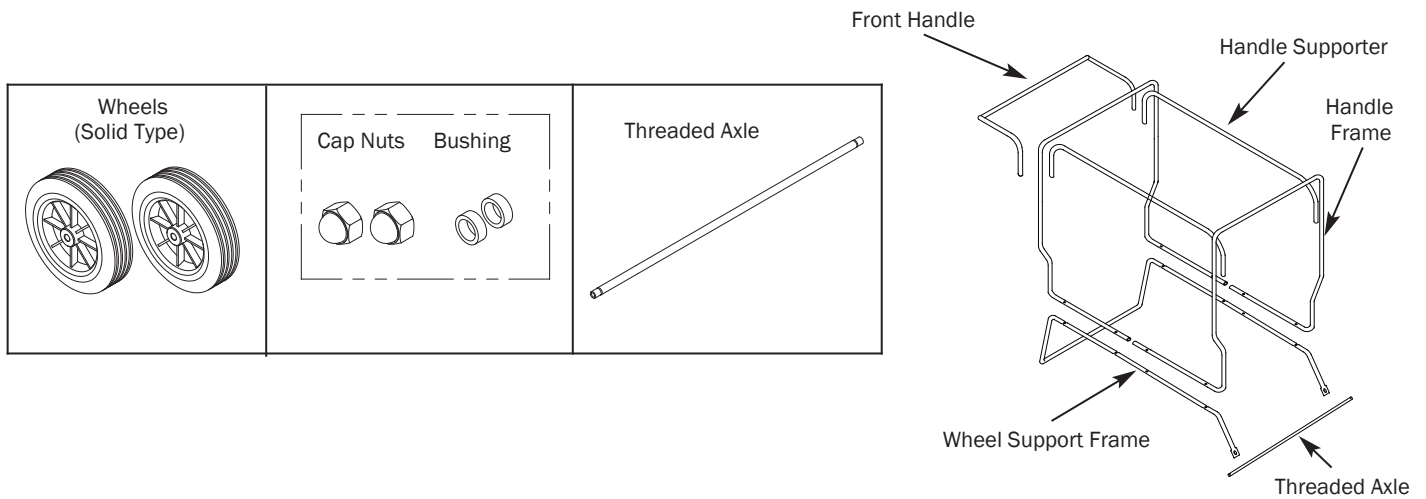

Figure 7 – Component Identification

ASSEMBLY FOR CP650DK

TOOLS REQUIRED

Adjustable wrench

ASSEMBLING WHEEL & HANDLE

1. Slide threaded axle through the rear section of the wheel support frame.
2. Slide one axle bushing on to each side of the axle. Slide one wheel on to each side of the axle. Attach one cap nut on to each side of the threaded axle and tighten well.
3. Loosen 4 screws on the front handle in order to remove handle front.
4. Move the removed handle front to the handle on the front side as Figure 8, and then tighten 4 screws after matching handle and handle front.

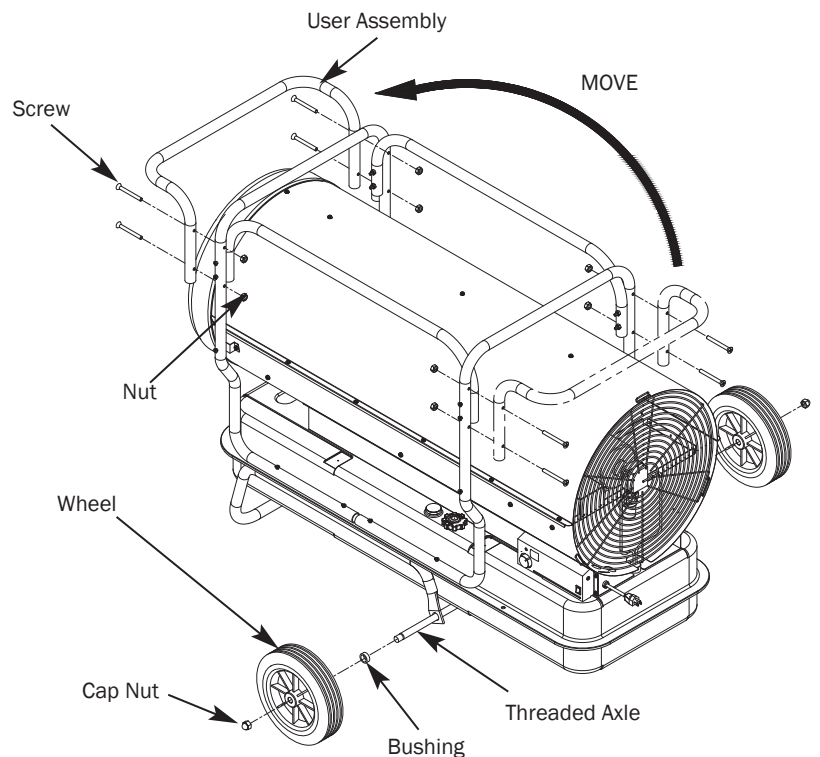
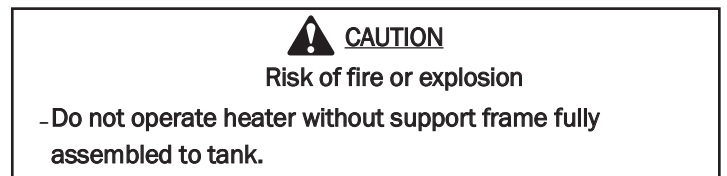

Figure 8– Wheel and Handle Assembly

OPERATION

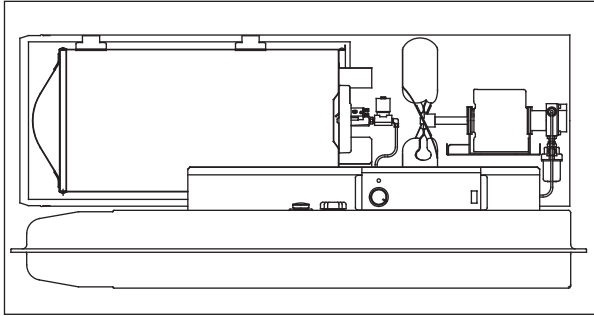

Figure 9 – Overview of Heater Design

OVERVIEW OF HEATER DESIGN

Fuel System: This heater is equipped with a fuel pump (Gear) that pulls fuel through the fuel line connected to the fuel tank and then pushes fuel through a filter and a solenoid valve and out the burner head nozzle.

This fuel is sprayed into the combustion chamber in a fine mist.

SureFire Ignition: The electronic ignitor sends voltage to a specially designed spark plug. The spark plug ignites the fuel and air mixture.

The Air System: The heavy duty motor turns a fan that forces air into and around the combustion chamber. Here, the air is heated and then forced out the front of the heater.

THE SAFETY SYSTEM

Temperature Limit Control: This heater is equipped with a Temperature Limit Control designed to turn the heater off should the internal temperature rise to an unsafe level. If this device activates and turns your heater off, it may require service.

Model	Internal Shut-off Temp. +/-10 Degrees	Reset Temp. +/-10 Degrees
CP400DK	176°F/80°C	122°F/50°C
CP650DK	160°F/71°C	120°F/49°C

Electrical System Protection: This heater's electrical system is protected by a fuse mounted to the PCB Assembly that protects it and other electrical components from damage.

If your heater fails to operate, check this fuse first and replace as needed. Refer to Specification chart on page 18.

Flame-Out Sensor: Utilizes a photocell to monitor the flame in burn chamber during normal operation. It will cause the heater to shut off should the burner flame extinguish.

FUEL SPECIFICATIONS

KEROSENE (1-K)

For optimal performance of this heater, it is strongly suggested that 1-K kerosene be used. 1-K kerosene has been refined to virtually eliminate contaminants, such as sulfur, which can cause a rotten egg odor during the operation of the heater. However, #1 or #2 fuel oil (diesel fuel) may also be used if 1-K kerosene is not available. **Be advised that these fuels do not burn as clean as 1-K kerosene, and care should be taken to provide more fresh air ventilation to accommodate any added contaminants that may be added to the heated space.**



WARNING!

Fire and explosion hazard!

- Kerosene should only be stored in a blue container that is clearly marked "kerosene". Never store kerosene in a red container. Red is associated with gasoline.
- NEVER store kerosene in the living space. Kerosene should be stored in a well ventilated area outside the living area.
- NEVER use fuel such as gasoline, benzene, alcohol, white gas, camp stove fuel, paint thinners, or other oil compounds in this heater (THESE ARE VOLATILE FUELS THAT CAN CAUSE A FIRE OR EXPLOSION).
- NEVER store kerosene in direct sunlight or near a source of heat.
- NEVER use kerosene that has been stored from one season to the next. Kerosene deteriorates over time. **OLD KEROSENE WILL NOT BURN PROPERLY IN THIS HEATER.**
- Use 1-K kerosene in this heater. #1 fuel is a suitable substitute.

OPERATION (cont.)

FUELING YOUR HEATER

Never fill the heater fuel tank in the living space: fill the tank outdoors.

Do not overfill your heater and be sure heater is level.



WARNING!

Fire and explosion hazard.

-Never refill fuel tank when heater is operating or still hot.

IMPORTANT: REGARDING FIRST IGNITION OF HEATER. The first time you light the heater, it should be done **OUTDOORS**. This allows the oils, etc., used in manufacturing heater to be burned off outside.

TO START HEATER

1. Fill fuel tank with kerosene or No. 1 fuel oil.
2. Attach fuel cap.
3. Plug power cord into three prong, grounded extension cord. Extension cord must be at least six feet long.
 - Extension Cord Wire Size Requirements:
 - 6 to 100 feet long, use 14 AWG conductor.
 - 101 to 200 feet long, use 12 AWG conductor.
 - 201 to 300 feet long, use 10 AWG conductor.
 - 301 to 400 feet long, use 8 AWG conductor.
 - 401 to 500 feet long, use 6 AWG conductor.

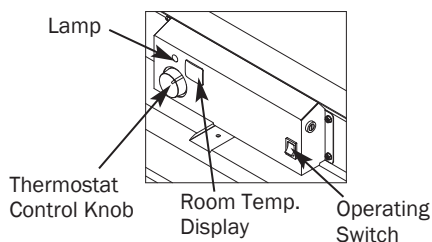

Figure 10 – Control Parts

4. Turn “THERMOSTAT CONTROL KNOB” to desired setting (setting range: 40° -110°F, 9 steps) and push operating switch to “ON” position. Power indicator lamp and room temperature display will light and heater will start.

If heater does not start, the thermo-stat setting may be too low, turn “THERMOSTAT CONTROL KNOB” to higher position to start heater. If heater still does not start, turn power switch to “OFF” and then to “ON” position (See Figure 10). If heater still does not start, see Troubleshooting Chart on page 20.

NOTE: Room Temp. display indicates as following:

- When room temp. is less than 0°F: “Lo”.
- When room temp. is between 0°F and 99°F: Indicates room temperatures.
- When room temp. is more than 99°F: “HI”.

NOTE: The major electrical components of this heater are protected by a circuit breaker mounted to the power switch. If your heater fails to start, check this first and replace as necessary. You should also check your power source to insure that proper voltage and frequency are being supplied to the heater.

TO STOP HEATER



CAUTION!

-Never unplug heater while running.

Heater must go through cooling cycle. The cooling cycle cools the combustion chamber. Damage to heater can occur if combustion chamber is not cooled. Do not restart heater until cooling cycle is complete.

1. Turn operating switch to “OFF”. This will cause heater flame to go out. The motor will continue to run during the cooling cycle. (Room Temp. Display will show “CC” during the cooling cycle). This allows the fan to cool the combustion chamber. When the cooling cycle (approx. 1Min) is finished, the motor will stop. Do not unplug heater until cooling cycle is finished.
2. Unplug power cord.
3. To temporarily stop heaters, set thermostat at a temperature lower than air around heater. Heater will cycle back on if air temperature around heater matches thermostat setting.

TO RESTART HEATER

The cooling cycle cools the combustion chamber.



CAUTION!

-DO NOT restart heater until cooling cycle is finished.

1. Wait until cooling cycle is finished after stopping heater.
2. Repeat steps under TO START HEATER.

OPERATION (cont.)



WARNING!

Shock hazard

-Always cover outlet when not in use.

PIGGYBACK POWER CORD

(For CP400DK only)

- Always cover electrical outlet when not in use. See Figure 11.
- Don't plug and use an appliance with more than 5A current in this outlet.

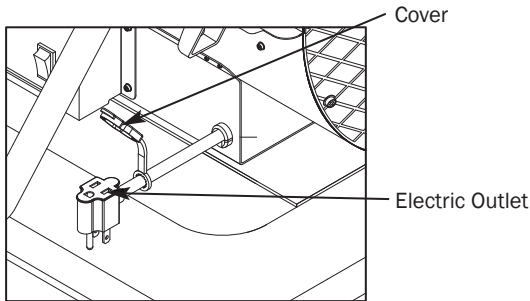

Figure 11 - Piggyback Power Cord

LONG-TERM STORAGE OF YOUR HEATER

FUEL TANK DRAIN

1. Remove drain bolt from bottom of fuel tank. See Figure 12.

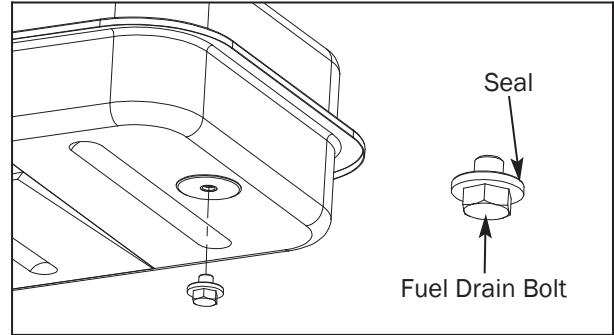

Figure 12 - Drain Plug Removal

2. Using a small amount of kerosene, swirl and rinse the inside of the tank.

NEVER MIX WATER WITH KEROSENE, as it will cause rust inside the tank. Pour the kerosene out, making sure that you remove it all.

IMPORTANT:

Do not store kerosene over summer for use during next heating season. Using old fuel may damage heater.

Tighten drain bolt firmly into the tank, otherwise it will not seal completely.

- Make sure storage place is free of dust and corrosive fumes.
- Store the heater in the original box with the original packing material and keep USER'S MANUAL with heater..

MAINTENANCE

USE ORIGINAL EQUIPMENT REPLACEMENT PARTS. Use of third-party or other alternate components will void warranty and may cause unsafe operating conditions.



WARNING

Fire or explosion hazard.

- Never service heater while it is plugged in or while hot!

UPPER SHELL REMOVAL

(For CP400DK only)

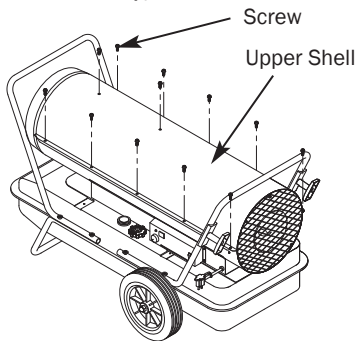

Figure 13 – Upper Shell Removal

- Remove screws along each side and top of heater using medium Phillips screwdriver.

(For CP650DK only)

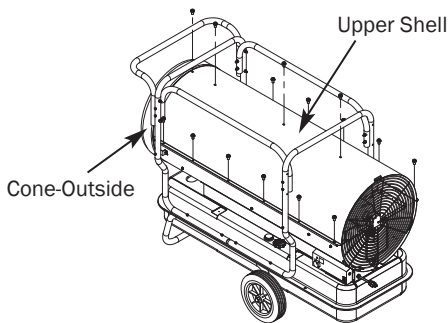

Figure 14 – Upper Shell Removal

- Remove screws of cone-outside and move up cone-outside after that remove screws along each side and top of heater using medium Phillips screwdriver.

FAN BLADES AND AIR DEFLECTOR

CLEAN EVERY SEASON OR AS NEEDED.

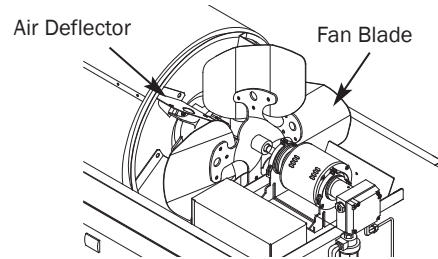

Figure 15 – Fan Blades and Air Deflectors

- Remove upper shell.
- Clean fan blades and air deflectors using soft cloth moistened with kerosene or solvent.
- Dry fan blades and air deflectors thoroughly.
- Reinstall upper shell.

MAINTENANCE (cont.)

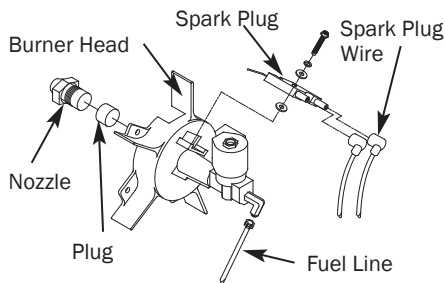

Figure 16 - Nozzle

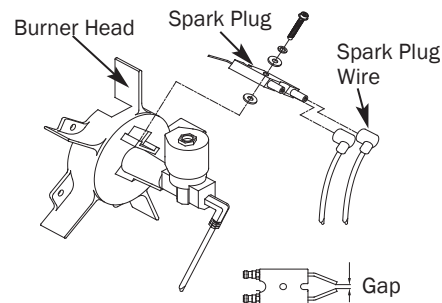

Figure 17 - Spark Plug

NOZZLE

REMOVE DIRT IN NOZZLE AS NEEDED.

- Remove upper shell.
- Remove fuel line from solenoid valve using 1/4" wrench.
- Remove spark plug wire from spark plug.
- Remove spark plug from burner head using medium Phillips screwdriver.
- Remove five screws using medium Phillips screwdriver and remove burner head from combustion chamber.
- Carefully remove nozzle from burner head using 5/8" socket wrench.
- Blow compressed air through face of nozzle (this will remove any dirt).
- Inspect nozzle for damage. If damaged or clogged, replace nozzle.
- Make sure plug is in place on burner head.
- Reinstall nozzle into burner head and tighten firmly (175-200 inch-pounds).
- Reinstall spark plug into burner head.
- Attach burner head to combustion chamber.
- Attach spark plug wire to spark plug.
- Attach fuel line to solenoid valve. Tighten firmly.
- Replace upper shell.

SPARK PLUG

CLEAN AND REGAP EVERY 600 HOURS OF OPERATION OR REPLACE AS NEEDED.

- Remove upper shell.
- Remove spark plug wire from spark plug (See Figure 17).
- Remove spark plug from burner head using medium Phillips screwdriver.
- Clean and regap spark plug electrodes to .140" (3.5 mm) gap.
- Reinstall spark plug into burner head.
- Attach spark plug wire to spark plug.
- Reinstall upper shell.

MAINTENANCE (cont.)

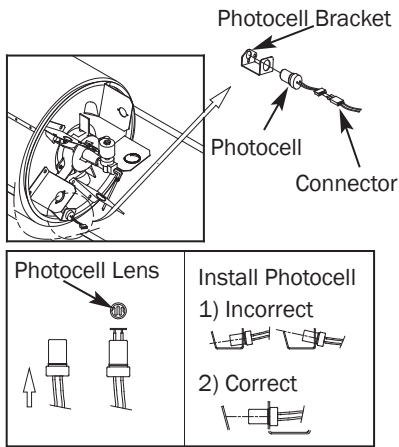

Figure 18 – Clean Photocell Lens

PHOTOCELL

CLEAN PHOTOCELL ANNUALLY OR AS NEEDED.

- Remove upper shell (See page 14).
- Remove photocell from photocell bracket and disconnect photocell from connector.
- Clean photocell lens with cotton swab.
- Inspect photocell for damage. If damaged, replace photocell.

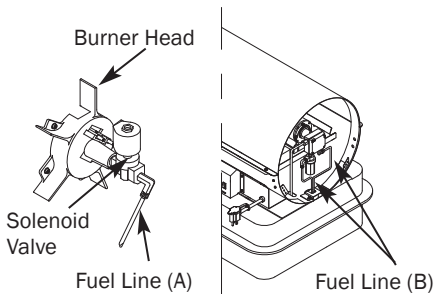

Figure 19 – Tighten Fuel Line

FUEL LINES

TIGHTEN FUEL LINES ANNUALLY OR AS NEEDED.

- Remove upper shell (See page 14).
- Use 1/4" wrench and tighten fuel line (A) at solenoid valve and at pump (See Figure 19).
- Remove fan guard (See Figure 20,21).
- Use 3/8" wrench and tighten fuel line (B) at pump and pump fuel filter assembly.
- Reinstall fan guard.

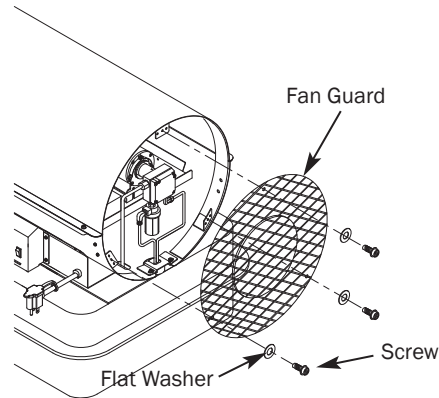

Figure 20 – Remove Fan Guard (CP400DK)

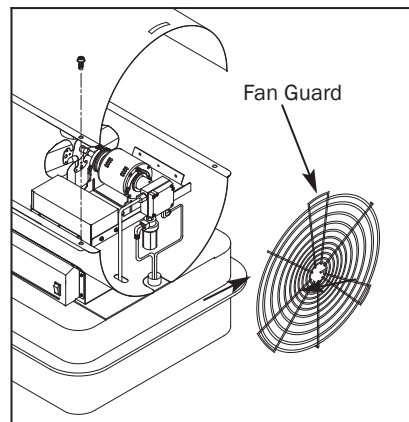

Figure 21 – Remove Fan Guard (CP650DK)

FUEL FILTER

CLEAN TWICE PER HEATING SEASON OR AS NEEDED.

Tank Fuel Filter

- Remove fan guard (See Figure 20,21).
- Disconnect fuel line (B) from pump and pump fuel filter assembly with 3/8" wrench (See Figure 19).
- Remove two screws that fix bracket-filter to shell lower and remove bracket-filter.
- Carefully pry fuel filter loose from fuel tank with flat end of screwdriver.
- Wash fuel lines and fuel filter with clean kerosene.
- Replace fuel filter into fuel tank.
- Replace bracket-filter to shell lower.
- Connect fuel lines (B) to pump and pump fuel filter assembly.
- Reinstall fan guard.

MAINTENANCE (cont.)

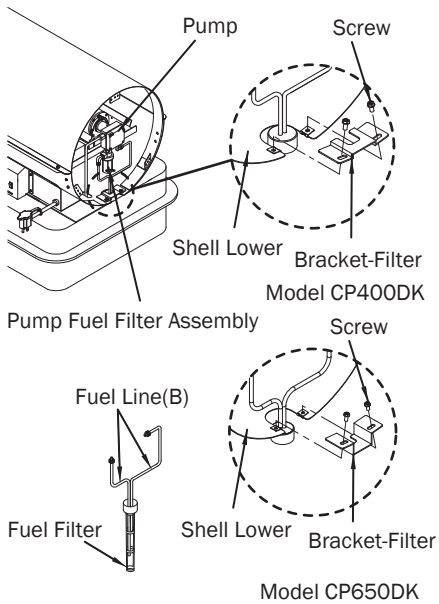

Figure 22 – Remove Tank Fuel Filter

Pump Fuel Filter

- Remove fan guard (See Figure 20,21).
- Unscrew filter bottom clockwise from filter top with adjustable pliers.
- Remove fuel filter, gasket, magnet from filter bottom (See Figure 22).
- Wash filter bottom with clean kerosene.
- Wipe inside of filter bottom dry with clean cloth.
- Wash Fuel filter in clean kerosene.
- Remove dirt attached to magnet.
- Put clean magnet, fuel filter and gasket back in filter bottom.
- Tighten firmly.

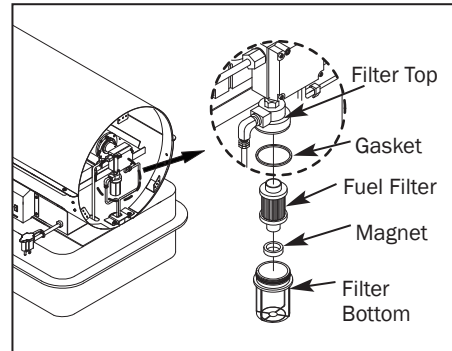

Figure 23 – Fuel Pump Filter

PUMP PRESSURE ADJUSTMENT

- Remove pressure gauge plug from pump with 1/8" Allen wrench.
- Install accessory pressure gauge to pressure gauge port (See Figure 23).
- Start heater (See Operation, Page 12). Allow motor to reach full speed.
- Adjust pressure (Using small flat blade screwdriver). Turn pressure adjustment screw clockwise to increase pressure. Turn screw counterclockwise to decrease pressure.
- Set pump pressure at 110 PSI (for CP650DK).
- Set pump pressure at 125 PSI (for CP400DK).
- Stop heater (See Operation, Page 12).
- Remove pressure gauge. Replace pressure gauge plug in pressure gauge port.

NOTE: Use only original equipment replacement parts. Use of alternate or third party components will void warranty and may cause an unsafe operating condition.

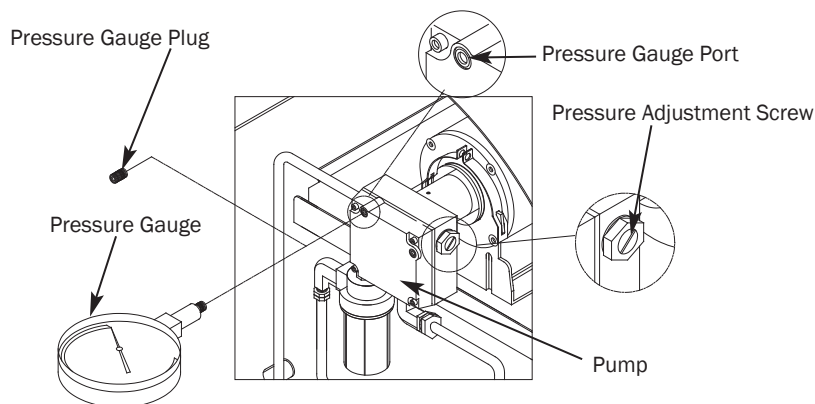

Figure 24 – Adjusting Pump Pressure

REPLACING FUSE

NOTE: The heater is fuse protected. If your heater fails to ignite, DO NOT RETURN YOUR HEATER TO THE STORE. Please follow the simple instructions below to inspect and change the fuse.

⚠ WARNING!
SHOCK HAZARD.
To prevent personal injury,
unplug the power cord before replacing fuse.

- Unplug heater.
- Turn Fuse Cover COUNTERCLOCKWISE 45° using a flat blade screwdriver and remove Fuse from Fuse Holder.
- Replace Fuse with enclosed fuse.

⚠ WARNING!
FIRE HAZARD. To avoid fire, Do not substitute
with a higher or lower current rating.

- Turn Fuse Cover CLOCKWISE 45° using a flat blade screwdriver while slightly pushing.

NOTE: Specified fuse rating: AC 250/20A

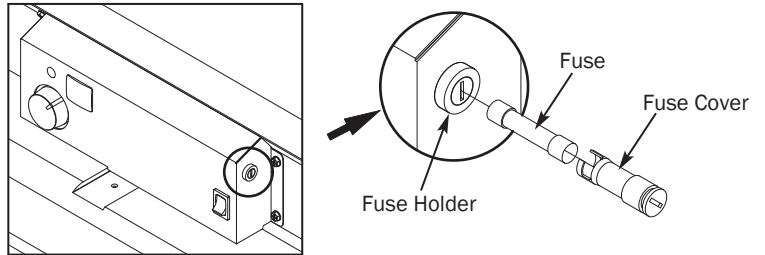

Figure 25 - Replacing Fuse

Wiring Diagram

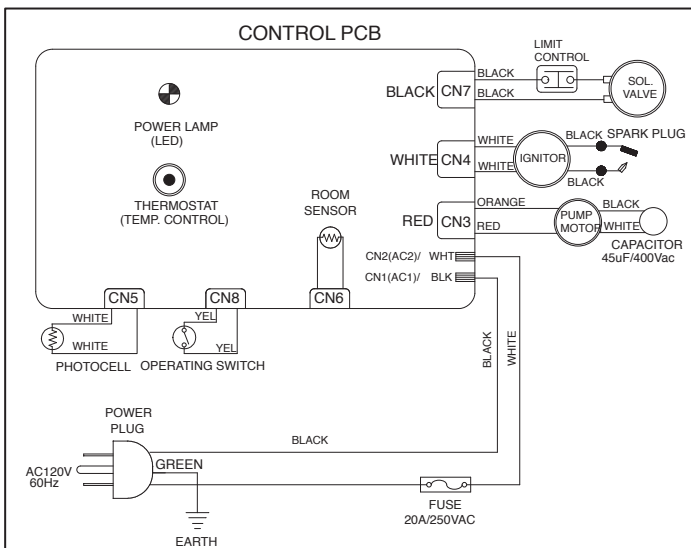

Figure 26 - Wiring Diagram Model CP400DK

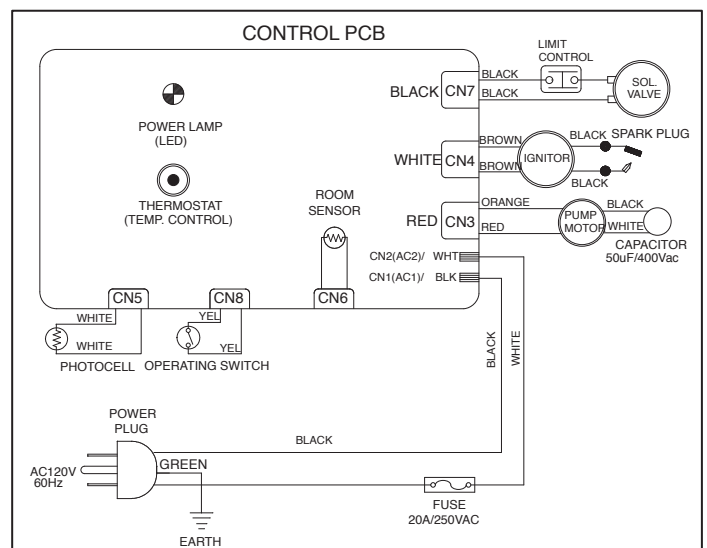

Figure 27 - Wiring Diagram Model CP650DK

Troubleshooting

Symptom	Possible Cause(s)	Corrective Action
Heater ignites but MAIN PCB assembly shuts heater off after a short period of time. (Indicator lamp is flickering and room temp. display indicates "E1")	<ol style="list-style-type: none"> 1. Wrong pump pressure 2. Dirty fuel filter 3. Dirt in nozzle 4. Dirty photocell lens 5. Photocell assembly not properly installed. (Not seeing the flame) 6. Bad electrical connection between photocell and MAIN PCB assembly 7. Defective photocell 8. Temperature limit safety device is overheated 	<ol style="list-style-type: none"> 1. See Pump Pressure Adjustment, page 17 2. Clean Fuel Filter, see page 16 3. Clean Nozzle, see page 15 4. Clean photocell lens, page 16 5. Make sure photocell boot is properly seated in bracket, see page 16 6. Check electrical connections. See Wiring Diagram, page 18 7. Replace photocell, page 16 8. Turn operating switch to "OFF" and allow to cool (about 10 min.). Then turn operating switch to "ON" position.
Heater will not ignite but motor runs for a short period of time. (Indicator lamp is flickering and room temp. display indicates "E1")	<ol style="list-style-type: none"> 1. No fuel in tank 2. Wrong pump pressure 3. Carbon deposits on spark plug and/or improper gap 4. Dirty fuel filter 5. Dirt in nozzle 6. Water in fuel tank 7. Bad electrical connection between ignitor and MAIN PCB assembly 8. Ignitor wire is not attached to spark plug 9. Defective ignitor 10. Defective solenoid valve (not opening) 11. Defective Ignition transformer. 	<ol style="list-style-type: none"> 1. Fill tank with kerosene 2. See Pump Pressure Adjustment, page 17 3. See Spark Plug, page 15 4. See Fuel Filter, page 16 5. See Nozzle, page 15 6. Flush fuel tank with clean kerosene, page 13 7. Check electrical connections. See Wiring Diagram, page 18 8. Attach ignitor wire to spark plug 9. Replace ignitor 10. Check electrical connections and voltage to solenoid valve. If defective, replace solenoid valve 11. Check power from board to ignition transformer.
Fan does not turn when heater is plugged in and power switch is in the "ON" position. (Indicator lamp is on or flickering)	<ol style="list-style-type: none"> 1. Thermostat setting is too low 2. Bad electrical connection between motor and MAIN PCB assembly 	<ol style="list-style-type: none"> 1. Turn thermostat control knob to a higher setting 2. Check electrical connections. See Wiring Diagram, page 18
(Indicator lamp is flickering and room temp. display indicates "E2")	<ol style="list-style-type: none"> 1. Sensor failure 	<ol style="list-style-type: none"> 1. Replace sensor. See Wiring Diagram, page 18
(Indicator lamp is flickering and room temp. display indicates "E3")	<ol style="list-style-type: none"> 1. Thermostat switch failure 	<ol style="list-style-type: none"> 1. Replace switch. See Wiring Diagram, page 18
Heater will not turn-on (Indicator lamp is off)	<ol style="list-style-type: none"> 1. No electrical power 2. Blown fuse 	<ol style="list-style-type: none"> 1. Check to insure heater cord and extension cord are plugged in. Check power supply. 2. Replace safety fuse on cover display.

Parts Identification

PARTS SCHEMATIC CP400DK

For Repair Parts,
call 1-800-345-7200

Please provide following information:

- Model number
- Serial number (if any)
- Part description and number as shown in parts list

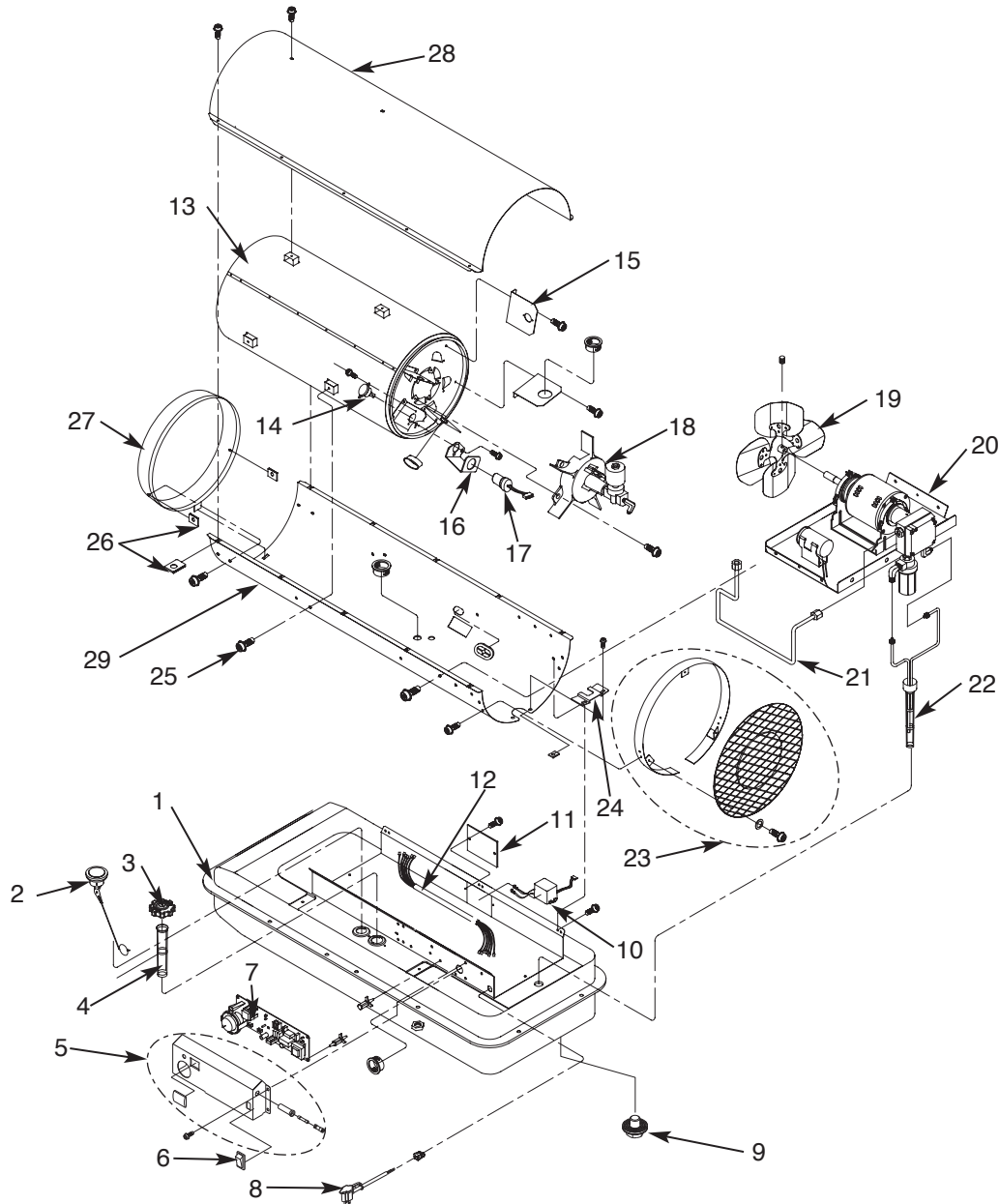

Figure 28- Repair Parts Illustration for Portable Oil-Fired Heaters Models CP400DK

PARTS LIST CP400DK

Reference Number	Description	Part Number for Models: CP400DK
1	Fuel Tank	572147
2	Fuel Gauge	572152
3	Fuel Cap	573414
4	Fuel Filling Filter	572156
5	Control Cover	572922
6	Operating Switch	572906
7	Main P.C.B. Assembly	573401
8	Power Cord	573415
9	Drain Plug	572450
10	Ignition Transformer	572299
11	Ignition Transformer Cover	572247
12	Burner Harness	572931
13	Combustion Chamber	572182
14	Temperature Limit Control	572297
15	Air Deflectors (Qty. 5)	572295
16	Photocell Bracket	572185
17	Photocell Assembly	572187
18	Burner Assembly	See Page 24
19	Fan Assembly	572236
20	Motor Assembly	See Page 25
21	Fuel Line	572289
22	Filler Neck Assembly	572286
23	Fan Guard Assembly	572268
24	Bracket-Filter	572738
25	Screw (12-pack)	572282
26	Clip Nut (6-pack)	572284
27	Outlet Cone	572293
28	Upper Shell	572303
29	Lower Shell	572167

Parts Identification

PARTS SCHEMATIC CP650DK

For Repair Parts,
call 1-800-345-7200

Please provide following information:

- Model number
- Serial number (if any)
- Part description and number as shown in parts list

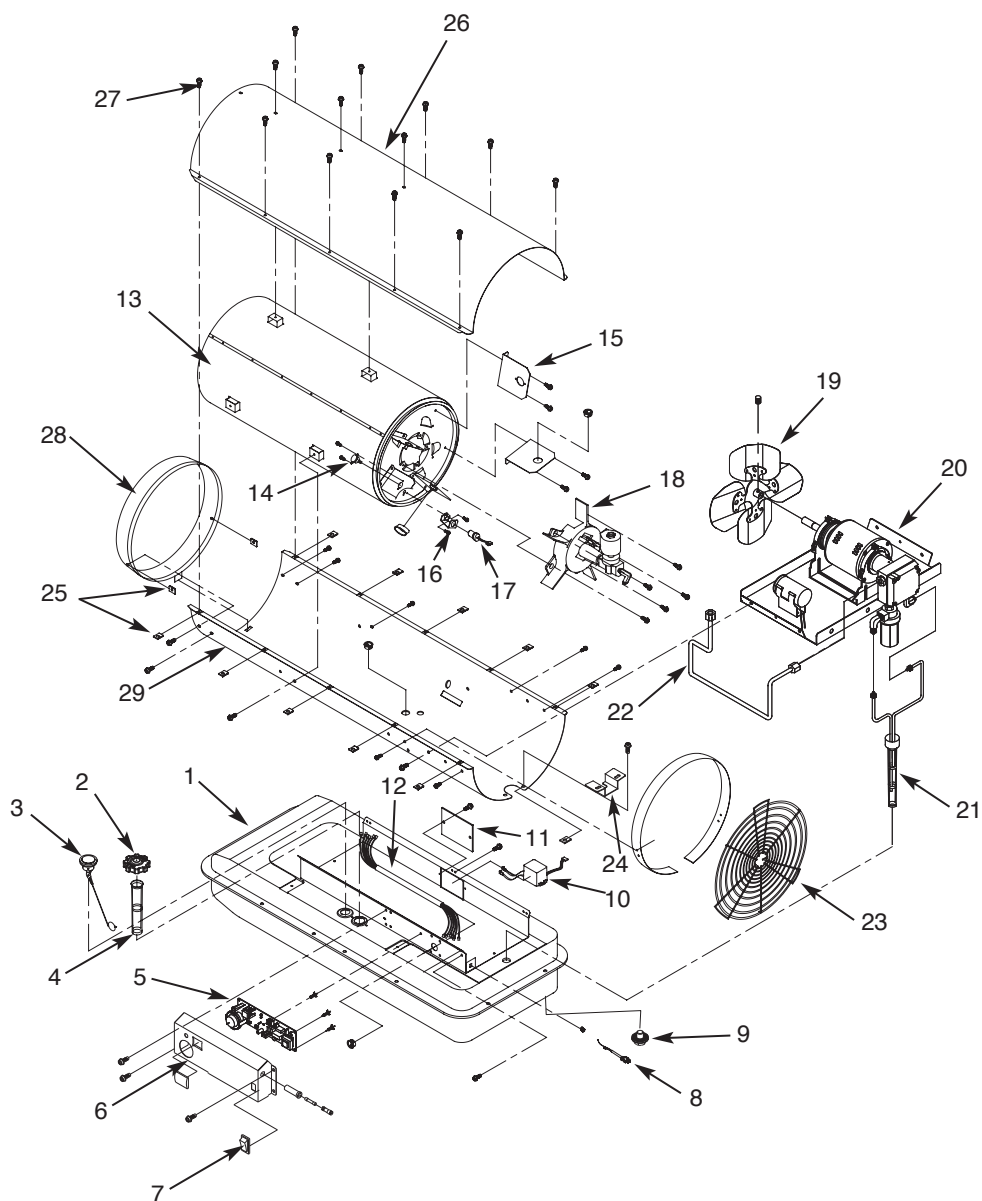

Figure 29— Repair Parts Illustration for Portable Oil-Fired Heaters Models CP650DK

PARTS LIST CP650DK

Reference Number	Description	Part Number for Models: CP650DK
1	Fuel Tank	572148
2	Fuel Cap	573414
3	Fuel Gauge	572153
4	Fuel Filling Filter	572156
5	Main P.C.B. Assembly	573400
6	Control Cover	572921
7	Operating Switch	572906
8	Power Cord	572161
9	Drain Plug	572450
10	Ignition Transformer	572300
11	Ignition Transformer Cover	572247
12	Burner Harness	572932
13	Combustion Chamber	572183
14	Temperature Limit Control	572298
15	Air Deflectors (Qty. 5)	572296
16	Photocell Bracket	572185
17	Photocell Assembly	572187
18	Burner Head Assembly	See Page 24
19	Fan Assembly	572237
20	Motor Assembly	See Page 25
21	Filler Neck Assembly	572287
22	Fuel Line	572290
23	Fan Guard Assembly	572269
24	Bracket-Filter	572739
25	Clip Nut (6-pack)	572284
26	Upper Shell	572304
27	Screw (12-pack)	572282
28	Outlet Cone	572294
29	Lower Shell	572168

Parts Identification

PARTS SCHEMATIC BURNER HEAD CP400DK/CP650DK

For Repair Parts,
call 1-800-345-7200

Please provide following information:

- Model number
- Serial number (if any)
- Part description and number as shown in parts list

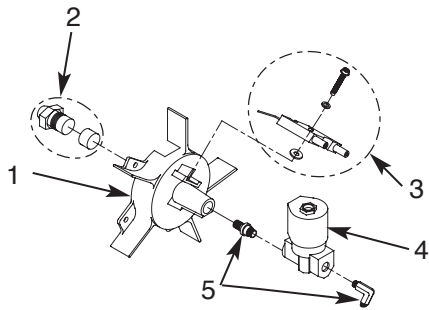

Ref. No.	Description	Part No. for Models:	
		CP400DK	CP650DK
1	Burner Head	-----572305-----	
2	Nozzle Assembly	572197	572198
3	Spark Plug Assembly	572201	572203
4	Solenoid	-----572308-----	
5	Solenoid Fittings	-----572309-----	

Figure 30- Burner head for CP400DK & CP650DK

Parts Identification

PARTS SCHEMATIC MOTOR ASSEMBLY CP400DK/CP650DK

**For Repair Parts,
call 1-800-345-7200**

Please provide following information:

- Model number
- Serial number (if any)
- Part description and number as shown in parts list

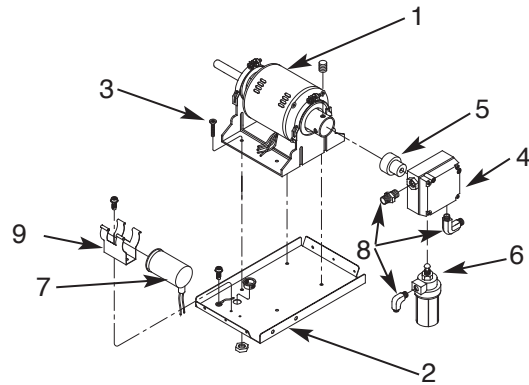

Ref. No.	Description	Part No. for Models:	
		CP400DK	CP650DK
1	Motor	572212	572213
2	Motor Support	572221	572222
3	Motor Hardware Kit	-----572310-----	
4	Fuel Pump	572306	572307
5	Motor/Pump Coupler Kit	-----572311-----	
6	Fuel Filter	-----572312-----	
7	Capacitor	572216	572217
8	Filter/Pump Fittings	-----572313-----	
9	Capacitor Holder	-----572250-----	

Figure 31- Motor assembly for CP400DK & CP650DK

Parts Identification

PARTS SCHEMATIC HANDLE / WHEELS ASSEMBLY CP400DK

For Repair Parts,
call 1-800-345-7200

Please provide following information:

- Model number
- Serial number (if any)
- Part description and number as shown in parts list

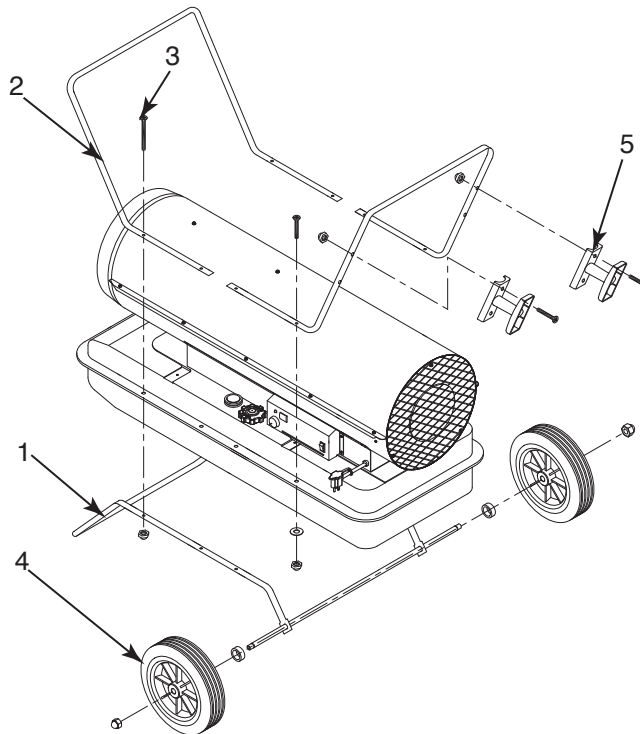

Ref. No.	Description	Part No. for Models: CP400DK
1	Wheel Support/Axle Kit	572741
2	Upper Handle Kit	572315
3	Hardware Kit	572314
4	Wheels Kit	572740
5	Cordwarp Kit	572318

Figure 32- Handle wheels assembly CP400DK

Parts Identification

PARTS SCHEMATIC HANDLE / WHEELS ASSEMBLY CP650DK

**For Repair Parts,
call 1-800-345-7200**

Please provide following information:

- Model number
- Serial number (if any)
- Part description and number as shown in parts list

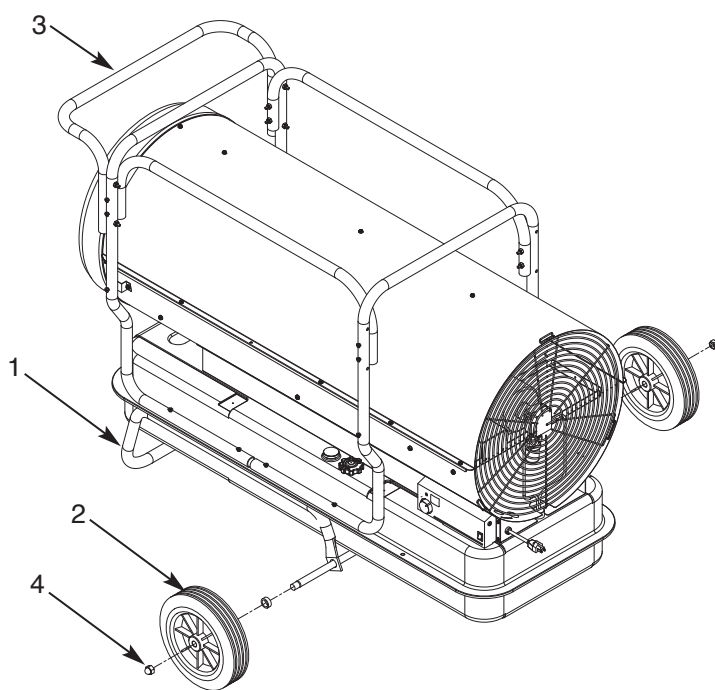

Ref. No.	Description	Part No. for Models: CP650DK
1	Wheel Support/Axle Kit	572321
2	Wheels Kit	572322
3	Upper Handle Kit	572320
4	Hardware Kit	572319

Figure 33– Handle wheels assembly CP650DK

Warranty Policy

EQUIPMENT

L.B. White Co., Inc. warrants that the component parts of its heater are free from defects in material and workmanship, when properly installed, operated, and maintained in accordance with the Owner's Manual safety guides and labels contained with each unit. If, **within 24 months from the date of purchase by the end user**, any component is found to be defective, L.B. White Co., Inc. will at its option, repair or replace the defective part or heater, with a new part or heater, F.O.B., Onalaska, Wisconsin, USA.

Registering your product online with L.B. White will automatically qualify a unit and its component parts for warranty consideration. If a product has not been registered with L.B.White, a copy of the bill of sale will be required to establish warranty qualification. If neither is available, the warranty period will be 24 months from date of shipment from L.B.White.

PARTS

L.B. White Co., Inc. warrants that replacement parts purchased from the company and used on the appropriate L. B. White heater are free from defects both in material and workmanship for **24 months from the date of purchase by the end user**. Warranty is automatic if a component is found defective within 24 months of the date code marked on the part. If the defect occurs more than 24 months later than the date code but within 24 months from the date of purchase by the end user, a copy of a bill of sale will be required to establish warranty qualification.

The warranty set forth above is the exclusive warranty provided by L.B. White, and all other warranties, including any implied warranties or merchantability or fitness for a particular purpose, are expressly disclaimed. In the event any implied warranty is not hereby effectively disclaimed due to operation of law, such implied warranty is limited in

duration to the duration of the applicable warranty stated above. The remedies set forth above are the sole and exclusive remedies available hereunder. L.B. White will not be liable for any incidental or consequential damages directly or indirectly related to the sale, handling or use of the heater, and in any event L.B. White's liability in connection with the heater, including for claims based on negligence or strict liability, is limited to the purchase price.

Some states do not allow limitations on how long an implied warranty lasts, so the above limitation may not apply to you. Some states do not allow the exclusion or limitation of incidental or consequential damages, so the above limitation or exclusion may not apply to you. This warranty gives you specific legal rights, and you may also have other rights which vary from state to state.

To register your product and ensure full warranty, go to <http://www.lbwhite.com/product-registration>. Please have the serial number(s) and model(s) handy for the products you are registering.

Replacement Parts and Service

Contact your local L.B. White dealer for replacement parts and service, you may also call L.B White Co., Inc. at (800)345-7200 for assistance or email to customerservice@lbwhite.com. Be sure that you have heater model number and configuration number when calling.