

# PORTABLE FORCED AIR HEATER

(WITH BUILT-IN THERMOSTAT)  
OWNER'S MANUAL

Heater Sizes:  
110,000, 115,000,  
150,000, 155,000,  
and 165,000 Btu/Hr  
H.S.I. Series

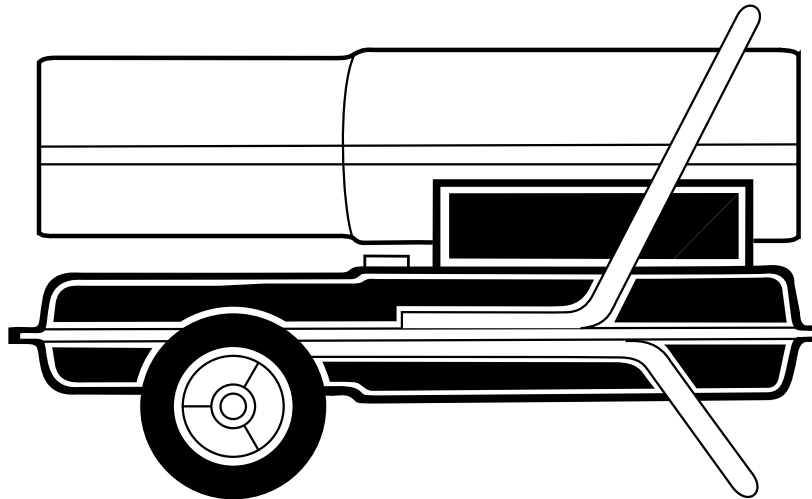

**IMPORTANT: Read and understand this manual before assembling, starting, or servicing heater. Improper use of heater can cause serious injury. Keep this manual for future reference.**

## TABLE OF CONTENTS

SAFETY INFORMATION .....	2	SERVICE PROCEDURES .....	7
UNPACKING .....	2	WIRING DIAGRAM .....	11
PRODUCT IDENTIFICATION .....	3	SPECIFICATIONS .....	11
ASSEMBLY .....	3	STORING, TRANSPORTING, OR SHIPPING .....	11
FUELS .....	4	ILLUSTRATED PARTS BREAKDOWN .....	12
VENTILATION .....	4	PARTS LIST .....	13
THEORY OF OPERATION .....	4	REPLACEMENT PARTS .....	15
OPERATION .....	4	TECHNICAL SERVICE .....	15
OPERATION WITH PORTABLE GENERATOR .....	5	ACCESSORIES .....	15
PREVENTATIVE MAINTENANCE SCHEDULE .....	5	WARRANTY AND REPAIR SERVICE .....	16
TROUBLESHOOTING .....	6		

**Fill In For Your Records**

Model No. \_\_\_\_\_  
(Located on side panel)

Serial No. \_\_\_\_\_  
(Located on fuel tank)



- SAFETY INFORMATION
- UNPACKING

## SAFETY INFORMATION

### WARNINGS

**IMPORTANT: Read this owner's manual carefully and completely before trying to assemble, operate, or service this heater. Improper use of this heater can cause serious injury or death from burns, fire, explosion, electrical shock, and carbon monoxide poisoning.**

** DANGER: Carbon monoxide poisoning may lead to death!**

**Carbon Monoxide Poisoning:** Early signs of carbon monoxide poisoning resemble the flu, with headaches, dizziness, and/or nausea. If you have these signs, the heater may not be working properly. **Get fresh air at once!** Have heater serviced. Some people are more affected by carbon monoxide than others. These include pregnant women, persons with heart or lung disease or anemia, those under the influence of alcohol, and those at high altitudes.

Make certain you read and understand all warnings. Keep this manual for reference. It is your guide to safe and proper operation of this heater.

- Use only kerosene or No. 1 fuel oil to avoid risk of fire or explosion. Never use gasoline, naphtha, paint thinners, alcohol, or other highly flammable fuels.
- Fueling
  - a) Personnel involved with fueling shall be qualified and thoroughly familiar with the manufacturer's instructions and applicable federal, state, and local regulations regarding the safe fueling of heating units.
  - b) Only the type of fuel specified on the heater's data plate shall be used.
- c) All flame, including the pilot light, if any, shall be extinguished and the heater allowed to cool, prior to fueling.
- d) During fueling, all fuel lines and fuel-line connections shall be inspected for leaks. Any leaks shall be repaired prior to returning the heater to service.
- e) At no time shall more than one day's supply of heater fuel be stored inside a building in the vicinity of the heater. Bulk fuel storage shall be outside the structure.
- f) All fuel storage shall be located a minimum of 25 feet from heaters, torches, welding equipment, and similar sources of ignition (exception: the fuel reservoir integral with the heater unit).
- g) Whenever possible, fuel storage shall be confined to areas where floor penetrations do not permit fuel to drip onto or be ignited by a fire at lower elevation.
- h) Fuel storage shall be in accordance with the federal, state, or local authority having jurisdiction.
- Never use heater where gasoline, paint thinner, or other highly flammable vapors are present.
- Follow all local ordinances and codes when using heater.
- Heaters used in the vicinity of tarpaulins, canvas, or similar enclosure materials shall be located a safe distance from such materials. The recommended minimum safe distance is 10 feet. It is further recommended that these enclosure materials be of a fire retardant nature. These enclosure materials shall be securely fastened to prevent them from igniting or from upsetting the heater due to wind action.
- Use only in well-vented areas. Before using heater, provide at least a three-square-foot opening of fresh, outside air for each 100,000 Btu/Hr of rating. This heater produces carbon monoxide, which is listed by the State of California as a reproductive toxin under Proposition 65.
- Use only in places free of flammable vapors or high dust content.
- Use only the electrical voltage and frequency specified on model plate.
- Use only a three-prong, grounded extension cord.
- Minimum heater clearances from combustibles:
 

Outlet: 8 Ft. Sides: 4 Ft.  
Top: 4 Ft. Rear: 4 Ft.
- Locate heater on a stable and level surface if heater is hot or running or a fire may occur.
- When moving or storing heater, keep heater in a level position or fuel spillage may occur.
- Keep children and animals away from heater.
- Unplug heater when not in use.
- When used with thermostat, heater may start anytime.
- Never use heater in living or sleeping areas.
- Never block air inlet (rear) or air outlet (front) of heater.
- Never move, handle, refuel, or service a hot, operating, or plugged-in heater.
- Never attach duct work to front or rear of heater.
- **Warning to New York City Residents For Use Only At Construction Sites** in accordance with applicable NYC codes under NYCFD certificate of approval #4803, #4899, #4908, #4909, or #4934.

## UNPACKING

1. Remove all packing items applied to heater for shipment.
2. Remove all items from carton.
3. Check items for shipping damage. If heater is damaged, promptly inform dealer where you bought heater.

## PRODUCT IDENTIFICATION

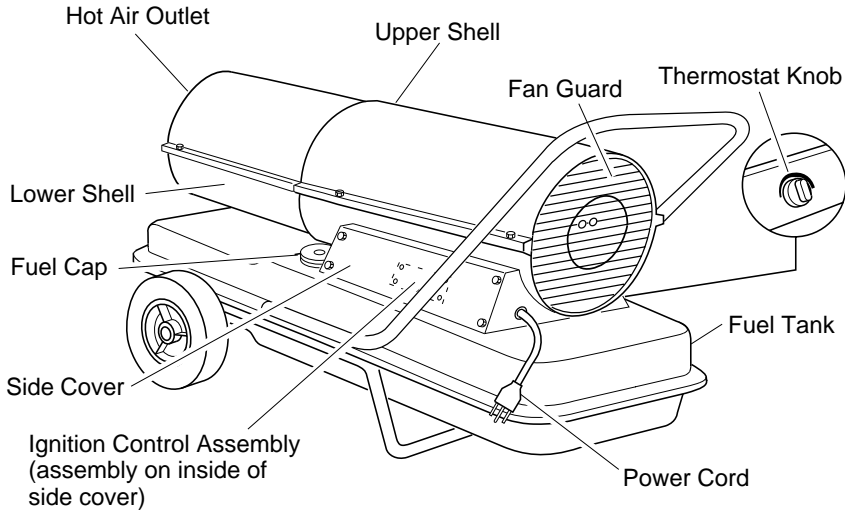

**Figure 1 - Portable Forced Air Heater**

## ASSEMBLY

These models are furnished with wheels and a rear handle. Some models are furnished with a front handle also. Wheels, handle(s), and the mounting hardware are found in the shipping carton.

### Tools Needed

- Medium Phillips Screwdriver
- 3/8" Open or Adjustable Wrench
- Hammer

1. Slide axle through wheel support frame. Install wheels on axle.

**IMPORTANT:** When installing wheels, point extended hub of wheels toward wheel support frame (see Figure 2).

2. Place cap nuts on axle ends. Gently tap with hammer to secure.
3. Place heater on wheel support frame. Make sure hot air outlet end (front) of heater is over wheels. Line up holes on fuel tank flange with holes on wheel support frame.
4. Place rear handle (and front handle if provided) on top of fuel tank flange. Insert screws through handle(s), fuel tank flange, and wheel support frame. Attach nut finger tight after each screw is inserted.
5. After all screws are inserted, tighten nuts firmly.

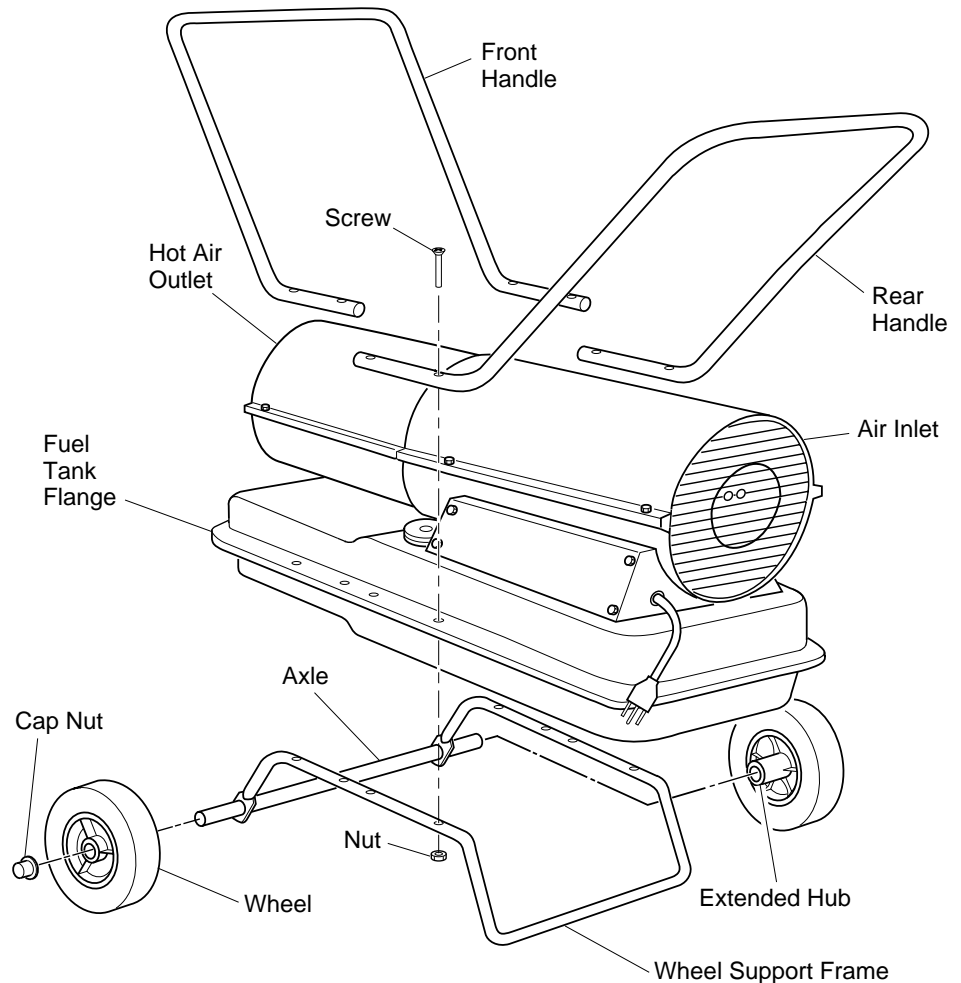

**Figure 2 - Wheel and Handle Assembly**

- FUELS
- VENTILATION
- THEORY OF OPERATION
- OPERATION

## FUELS

**⚠ WARNING: Use only kerosene or No. 1 fuel oil to avoid risk of fire or explosion. Never use gasoline, naphtha, paint thinners, alcohol, or other highly flammable fuels.**

Do not use heavy fuels such as No. 2 fuel oil or No. 2 Diesel. Using heavy fuels will result in a clogged fuel filter and/or nozzle.

**IMPORTANT:** Use a KEROSENE ONLY storage container. Be sure storage container is clean. Foreign matter such as rust, dirt, or water will cause the ignition control assembly to shut down the heater. Foreign matter may also require you to clean fuel system often.

## VENTILATION

**⚠ WARNING: Follow the minimum fresh, outside air ventilation requirements. If proper fresh, outside air ventilation is not provided, carbon monoxide poisoning can occur. Provide proper fresh, outside air ventilation before running heater.**

Provide at least a three-square-foot opening of fresh, outside air for each 100,000 Btu/Hr rating. Provide extra fresh air if more heaters are being used.

**Example:** A 165,000 Btu/Hr heater requires one of the following:

- a two-car garage door (16 feet wide opening) raised 4 inches
- a single-car garage door (9 feet wide opening) raised 7 inches
- two 30 inch wide windows raised twelve inches

## THEORY OF OPERATION

**The Fuel System:** The air pump forces air through the air line. The air is then pushed through the nozzle. This air causes fuel to lift from the tank. A fine mist of fuel is sprayed into the combustion chamber.

**The Air System:** The motor turns the fan. The fan pushes air into and around the combustion chamber. This air is heated and provides a stream of clean, hot air.

**The Ignition System:** The ignition control assembly provides power to the ignitor. This ignites the fuel/air mixture in the combustion chamber.

**The Flame-Out Control System:** This system causes the heater to shut down if the flame goes out.

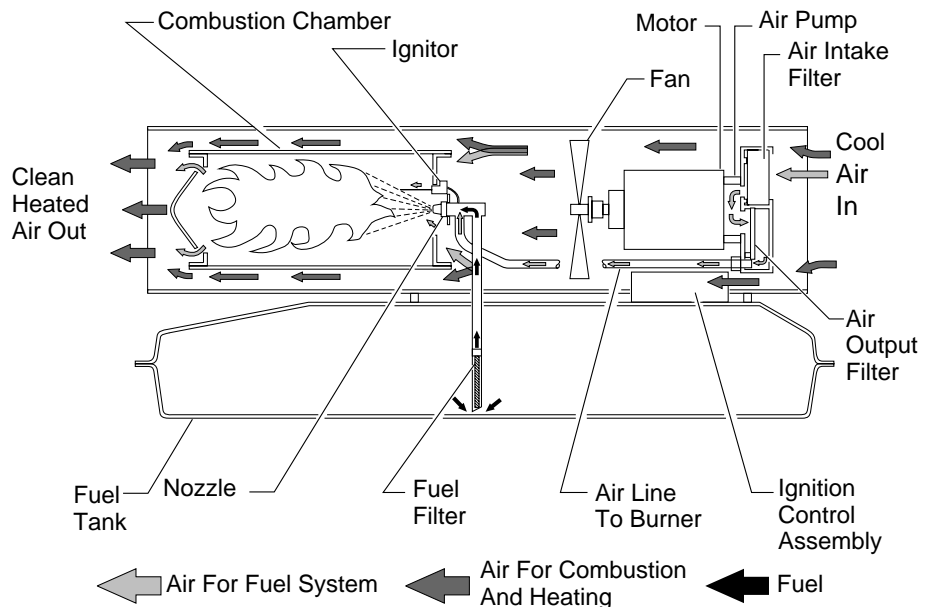

**Figure 3 - Cross Section Operational View**

## OPERATION

**⚠ WARNING: Review and understand the warnings in the Safety Information section, page 2. They are needed to safely operate this heater. Follow all local codes when using this heater.**

### TO START HEATER

1. Follow all ventilation and safety information.
2. Fill fuel tank with kerosene or No. 1 fuel oil.
3. Attach fuel cap.
4. Turn thermostat knob clockwise to the HIGH position.
5. Plug power cord of heater into three-prong, grounded extension cord. Extension cord must be at least six feet long.

### Extension Cord Wire Size Requirements

- 6 to 10 feet long, use 18 AWG rated cord
  - 11 to 100 feet long, use 16 AWG rated cord
  - 101 to 200 feet long, use 14 AWG rated cord
6. Plug extension cord into standard 120 volt/60 hertz, three-hole, grounded outlet. **Note:** Ignitor will preheat for five seconds then heater will start.
  7. Adjust thermostat knob to the desired setting.

**Note:** A cold heater may affect the thermostat setting. This thermostat is a general-heating control. It is not intended for precise temperature control. Adjust thermostat until heater cycles at the desired setting.

- OPERATION
- OPERATION WITH PORTABLE GENERATOR
- PREVENTATIVE MAINTENANCE SCHEDULE

## OPERATION

### *Continued*

#### TO STOP HEATER

Unplug extension cord from outlet.

#### TO RESET HEATER

1. Unplug extension cord from outlet and wait 10 seconds (two minutes if heater has been running).
2. Turn thermostat knob clockwise to the HIGH position.
3. Plug extension cord into standard 120 volt/60 hertz, three-hole, grounded outlet. *Note:* Ignitor will preheat for five seconds then heater will start.
4. Adjust thermostat knob to the desired setting.

## OPERATION WITH PORTABLE GENERATOR

**⚠ WARNING: Before operating heater or any appliance from a portable generator, verify that generator has been properly connected to earth ground. Improper grounding or failure to ground generator can result in electrocution if a ground fault occurs. Refer to owner's manual supplied by generator manufacturer for proper grounding procedures.**

The operating voltage range of the heater is 108 to 132 Volts (120 Volts +/- 10%). Prior to plugging heater into generator the output voltage should be verified (if generator is equipped with the automatic idle feature, the output voltage should be measured with the generator running at full speed). If the voltage does not measure in this range the heater should not be plugged into the generator.

Refer to *Operation*, pages 4 and 5, for starting, stopping, and resetting heater procedures.

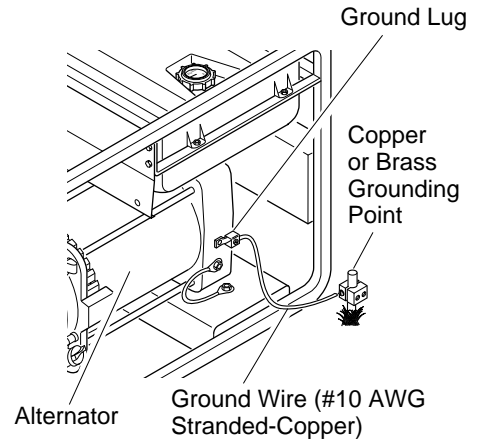

**Figure 4 - Typical Generator Grounding Method (Generator construction may vary from that shown)**

## PREVENTATIVE MAINTENANCE SCHEDULE

**⚠ WARNING: Never service heater while it is plugged in, operating, or hot. Severe burns and electrical shock can occur.**

Item	How Often	How To
Fuel tank	Flush every 150-200 hours of operation or as needed	See <i>Storing, Transporting, or Shipping</i> , page 11
Air output and lint filters	Replace every 500 hours of operation or once a year	See <i>Air Output, Air Intake, and Lint Filters</i> , page 7
Air intake filter	Wash and dry with soap and water every 500 hours of operation or replace as needed	See <i>Air Output, Air Intake, and Lint Filters</i> , page 7
Fuel filter	Clean twice a heating season or replace as needed	See <i>Fuel Filter</i> , page 8
Ignitor	No maintenance required	
Fan blades	Clean each season or as needed	See <i>Fan</i> , page 7
Motor	Not required/permanently lubricated	

## TROUBLESHOOTING

*Note:* For additional help, visit DESA International's technical service web site at [www.desatech.com](http://www.desatech.com).

**⚠ WARNING: Never service heater while it is plugged in, operating, or hot. Severe burns and electrical shock can occur.**

FAULT CONDITION	POSSIBLE CAUSE	REMEDY
Motor does not start five seconds after heater is plugged in	<ol style="list-style-type: none"> <li>1. No power to heater</li> <li>2. Thermostat setting too low</li> </ol>	<ol style="list-style-type: none"> <li>1. Check circuit breaker in electrical panel</li> <li>2. Turn thermostat knob to a higher setting</li> </ol>
<b>⚠ WARNING: High voltage!</b>		
	<ol style="list-style-type: none"> <li>3. Bad electrical connection between motor and ignition control assembly or ignition control assembly and power cord</li> <li>4. Blown fuse on ignition control assembly</li> <li>5. Binding pump rotor</li> <li>6. Defective ignition control assembly</li> <li>7. Defective motor</li> </ol>	<ol style="list-style-type: none"> <li>3. Check all electrical connections. See <i>Wiring Diagram</i>, page 11</li> <li>4. See <i>Ignition Control Assembly</i>, page 10</li> <li>5. If fan does not turn freely, see <i>Pump Rotor</i>, page 10</li> <li>6. Replace ignition control assembly</li> <li>7. Replace motor</li> </ol>
Motor starts and runs but heater does not ignite	<ol style="list-style-type: none"> <li>1. No fuel in tank</li> <li>2. Pump pressure incorrect</li> <li>3. Dirty fuel filter</li> <li>4. Obstruction in nozzle assembly</li> <li>5. Water in fuel tank</li> </ol>	<ol style="list-style-type: none"> <li>1. Fill tank with kerosene</li> <li>2. See <i>Pump Pressure Adjustment</i>, page 7</li> <li>3. See <i>Fuel Filter</i>, page 8</li> <li>4. See <i>Nozzle Assembly</i>, page 9</li> <li>5. Drain and flush fuel tank with clean kerosene. See <i>Storing, Transporting, or Shipping</i>, page 11</li> </ol>
<b>⚠ WARNING: High voltage!</b>		
	<ol style="list-style-type: none"> <li>6. Bad electrical connection between ignitor and ignition control assembly</li> <li>7. Defective ignitor</li> <li>8. Defective ignition control assembly</li> </ol>	<ol style="list-style-type: none"> <li>6. Check electrical connections. See <i>Wiring Diagram</i>, page 11</li> <li>7. Replace ignitor, see page 8</li> <li>8. Replace ignition control assembly</li> </ol>
Heater ignites but ignition control assembly shuts heater off after a short period of time	<ol style="list-style-type: none"> <li>1. Pump pressure incorrect</li> <li>2. Dirty air intake, air output, and/or lint filter</li> <li>3. Dirty fuel filter</li> <li>4. Obstruction in nozzle assembly</li> <li>5. Photocell assembly not properly installed (not seeing the flame)</li> </ol>	<ol style="list-style-type: none"> <li>1. See <i>Pump Pressure Adjustment</i>, page 7</li> <li>2. See <i>Air Output, Air Intake, and Lint Filters</i>, page 7</li> <li>3. See <i>Fuel Filter</i>, page 8</li> <li>4. See <i>Nozzle Assembly</i>, page 9</li> <li>5. Make sure photocell boot is properly seated in bracket</li> </ol>
<b>⚠ WARNING: High voltage!</b>		
	<ol style="list-style-type: none"> <li>6. Dirty photocell lens</li> <li>7. Bad electrical connection between photocell and ignition control assembly</li> <li>8. Defective photocell</li> <li>9. Defective ignition control assembly</li> </ol>	<ol style="list-style-type: none"> <li>6. Clean photocell lens</li> <li>7. Check electrical connections. See <i>Wiring Diagram</i>, page 11</li> <li>8. Replace photocell</li> <li>9. Replace ignition control assembly</li> </ol>

## SERVICE PROCEDURES

**⚠ WARNING:** Never service heater while it is plugged in, operating, or hot. Severe burns and electrical shock can occur.

### UPPER SHELL REMOVAL

1. Remove screws along each side of heater using 5/16" nut-driver. These screws attach upper and lower shells together.
2. Lift upper shell off.
3. Remove fan guard.

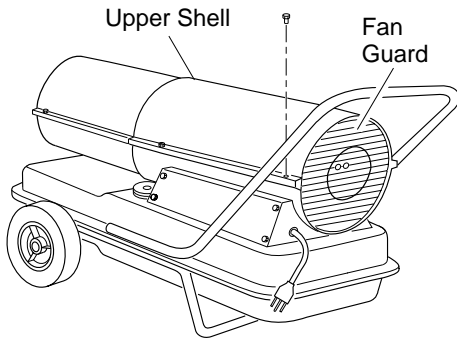

Figure 5 - Upper Shell Removal

### FAN

**IMPORTANT:** Remove fan from motor shaft before removing motor from heater. The weight of the motor resting on the fan could damage the fan pitch.

1. Remove upper shell (see above).
2. Use 1/8" Allen wrench to loosen set-screw which holds fan to motor shaft.
3. Slip fan off motor shaft.
4. Clean fan using soft cloth moistened with kerosene or solvent.
5. Dry fan thoroughly.
6. Replace fan on motor shaft. Place fan hub flush with end of motor shaft (see Figure 6).
7. Place setscrew on flat of shaft. Tighten setscrew firmly (40-50 inch-pounds).
8. Replace fan guard and upper shell.

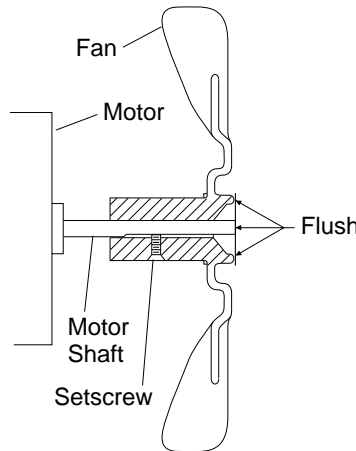

Figure 6 - Fan Cross Section

### AIR OUTPUT, AIR INTAKE, AND LINT FILTERS

1. Remove upper shell (see *Upper Shell Removal*).
2. Remove filter end cover screws using 5/16" nut-driver.
3. Remove filter end cover.
4. Replace air output and lint filters.
5. Wash or replace air intake filter (see *Preventative Maintenance Schedule*, page 5).
6. Replace filter end cover.
7. Replace fan guard and upper shell. **IMPORTANT:** Do not oil filters.

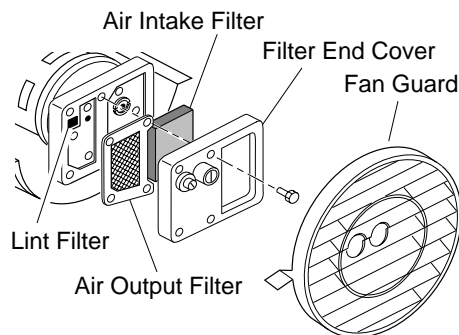

Figure 7 - Air Output, Air Intake, and Lint Filters

### PUMP PRESSURE ADJUSTMENT

1. Remove pressure gauge plug from filter end cover.
2. Install accessory pressure gauge (part number HA1180).
3. Start heater (see *Operation*, pages 4 and 5). Allow motor to reach full speed.
4. Using a flat blade screwdriver, adjust pressure. Turn relief valve to right to increase the pressure. Turn relief valve to left to decrease the pressure. Set pump pressure at 5.3 for 110,000 and 115,000 Btu/Hr models, 5.4 PSI for 150,000 and 155,000 Btu/Hr models, and 5.6 PSI for 165,000 Btu/Hr models.
5. Stop heater (see *Operation*, pages 4 and 5).
6. Remove pressure gauge. Replace pressure gauge plug in filter end cover.

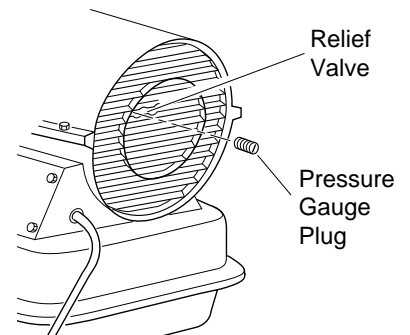

Figure 8 - Pressure Gauge Plug Removal

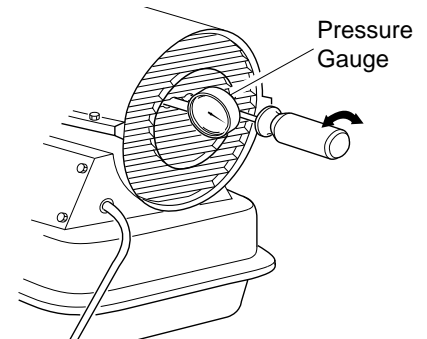

Figure 9 - Adjusting Pump Pressure

Continued

## SERVICE PROCEDURES

### Continued

**⚠ WARNING: Never service heater while it is plugged in, operating, or hot. Severe burns and electrical shock can occur.**

### FUEL FILTER

1. Remove side cover screws using 5/16" nut-driver.
2. Remove side cover.
3. Pull upper fuel line off fuel filter neck.
4. Carefully pry bushing, fuel filter, and lower fuel line out of fuel tank.
5. Wash fuel filter with clean fuel and replace in tank.
6. Attach upper fuel line to fuel filter neck.
7. Replace side cover.

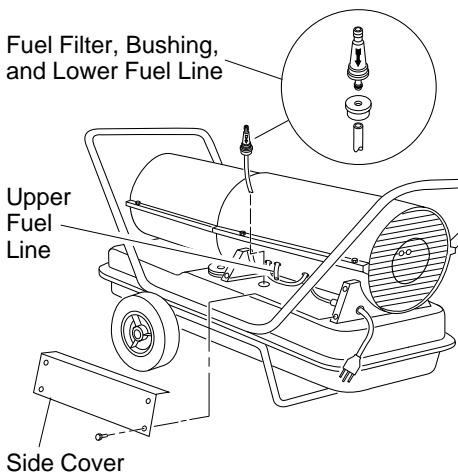

**Figure 10 - Fuel Filter Removal**

### IGNITOR

1. Remove upper shell and fan guard (see page 7).
2. Remove fan (see page 7).
3. Remove 4 side cover screws with a 5/16" nut driver. Remove side cover (see Figure 10).
4. Disconnect ignitor wires (yellow) from ignition control assembly (see Figure 11). Pull the ignitor wires up through the hole in the lower shell.
5. Disconnect fuel line hose and air line hose. Remove photocell from photocell bracket (see Figure 11).
6. Remove combustion chamber. Stand combustion chamber on end with nozzle adapter bracket on top (see Figure 12).
7. Remove ignitor screw with a 1/4" nut driver. Carefully remove ignitor from nozzle adapter bracket.

**⚠ CAUTION: Do not bend or strike ignitor element. Handle with care.**

8. Carefully remove replacement ignitor from styrofoam packing.
9. Carefully guide ignitor into opening in nozzle adapter bracket. Do not strike ignitor element. Attach ignitor to nozzle adapter bracket with screw using a 1/4" nut driver (see Figure 12). Torque 8 to 15 in. lbs. Do not over torque.
10. Replace combustion chamber.
11. Route the ignitor wires back down through the hole in the lower shell. Connect wires to the ignition control assembly.
12. Replace side cover (see Figure 10).
13. Connect fuel line hose and air line hose to nozzle assembly. See *Fuel and Air Line Replacement and Proper Routing*, page 9.
14. Replace photocell in photocell bracket.
15. Replace fan (see page 7).
16. Replace fan guard and upper shell (see page 7).

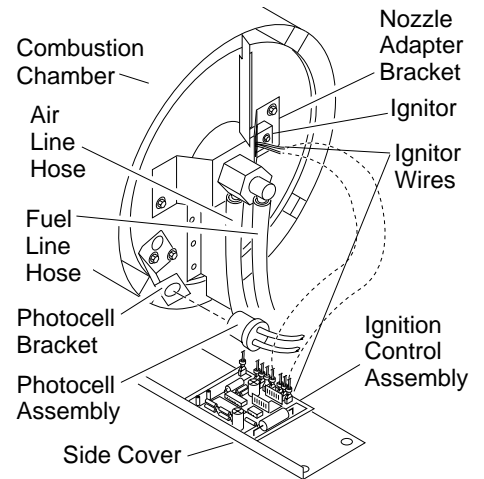

**Figure 11 - Disconnecting Ignitor Wires from Ignition Control Assembly**

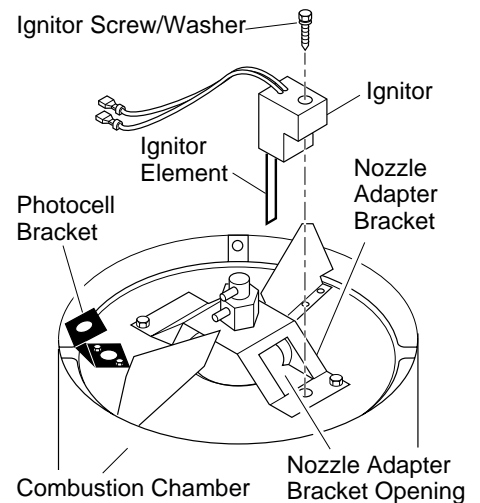

**Figure 12 - Ignitor Replacement**



# SERVICE PROCEDURES

## Continued

### NOZZLE ASSEMBLY

1. Remove upper shell (see page 7).
2. Remove fan (see page 7).
3. Remove fuel and air line hoses from nozzle assembly (see Figure 13 or 14).
4. Turn nozzle assembly 1/4 turn to left and pull toward motor to remove (see Figure 15).
5. Place plastic hex-body into vise and lightly tighten.
6. Carefully remove nozzle from the nozzle adapter using 5/8" socket wrench (see Figure 16).
7. Blow compressed air through face of nozzle. This will free any dirt in nozzle area.
8. Inspect nozzle seal for damage.
9. Replace nozzle into nozzle adapter until nozzle seats. Tighten 1/3 turn more using 5/8" socket wrench (40-45 inch-pounds). See Figure 16.
10. Attach nozzle assembly to burner strap.
11. Attach fuel and airline hoses to nozzle assembly. See *Fuel and Air Line Replacement and Proper Routing*.
12. Replace fan (see page 7).
13. Replace fan guard and upper shell.

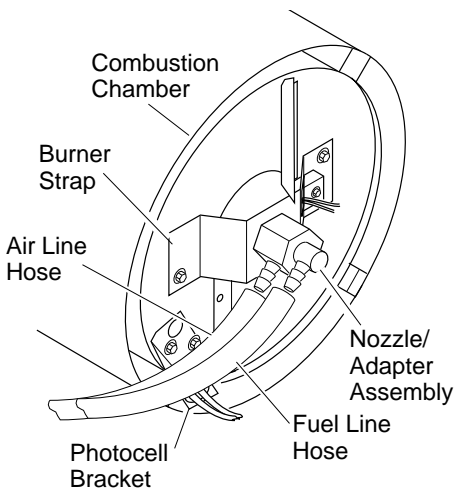

**Figure 13 - Removing Air and Fuel Line Hoses (110,000 and 115,000 Btu/Hr Models Only)**

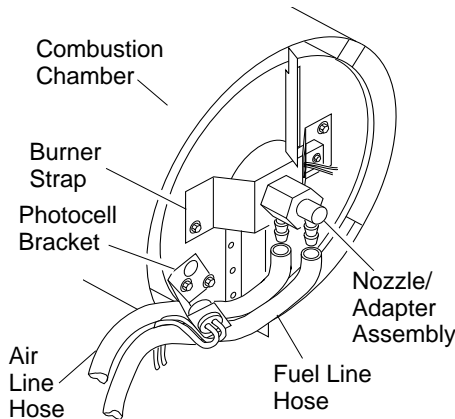

**Figure 14 - Removing Air and Fuel Line Hoses (150,000, 155,000 and 165,000 Btu/Hr Models Only)**

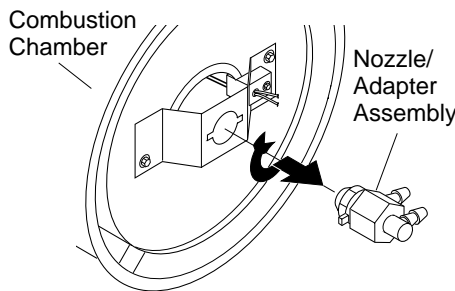

**Figure 15 - Removing Nozzle/Adapter Assembly**

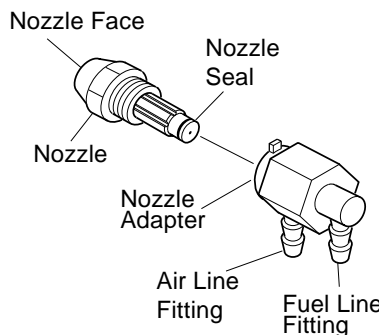

**Figure 16 - Nozzle and Nozzle Adapter**

### FUEL AND AIR LINE REPLACEMENT AND PROPER ROUTING

1. Remove upper shell (see page 7).
  2. Remove side cover screws using 5/16" nut driver
  3. Remove side cover.
  4. Inspect fuel and air line hoses for cracks and/or holes. If fuel line hose is damaged, disconnect from nozzle adapter (see Figure 13 or 14) and from fuel filter (see page 8). If air line hose is damaged, disconnect from nozzle adapter (see Figure 13 or 14) and from barb fitting on pump end cover (see Figure 17).
  5. Install new air and/or fuel line. Attach one end of air line hose to barb fitting on pump end cover (see Figure 17) and the other end to nozzle adapter (see Figure 13 or 14). Attach one end of fuel line hose to fuel filter (see page 8) and the other end to nozzle adapter (see Figure 13 or 14). Route air and fuel line approximately as shown in Figure 13 or 14.
- Note:** Hoses are not to be touching photocell bracket.
6. Replace side cover.
  7. Replace upper shell and fan guard (see page 7).

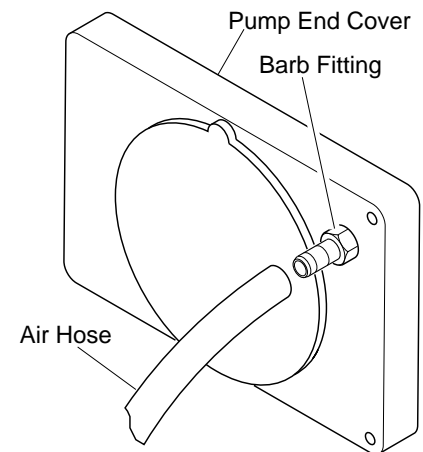

**Figure 17 - Air Hose to Barb Fitting**

Continued

## SERVICE PROCEDURES Continued

### PUMP ROTOR (Procedure if Rotor is Binding)

1. Remove upper shell (see page 7).
2. Remove filter end cover screws using 5/16" nut-driver.
3. Remove filter end cover and air filters (see Figure 18).
4. Remove pump plate screws using 5/16" nut-driver.
5. Remove pump plate.
6. Remove rotor, insert, and blades.
7. Check for debris in pump. If debris is found, blow out with compressed air.
8. Install insert and rotor.
9. Check gap on rotor. Adjust to .003"/.004" if needed (see Figure 19).  
**Note:** Rotate rotor one full turn to insure the gap is .003"/.004" at tightest position. Adjust if needed.
10. Install blades, pump plate, air filters, and filter end cover.
11. Replace fan guard and upper shell.
12. Adjust pump pressure (see page 7).  
**Note:** If rotor is still binding, proceed as follows.
13. Perform steps 1 through 6 above.
14. Place fine grade sandpaper (600 grit) on flat surface. Sand rotor lightly in "figure 8" motion four times (see Figure 20).
15. Reinstall insert and rotor.
16. Perform steps 10 through 12 above.

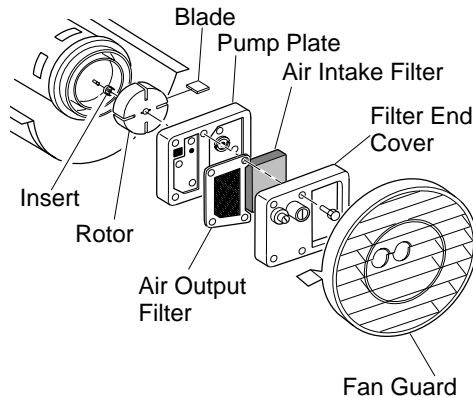

Figure 18 - Rotor Location

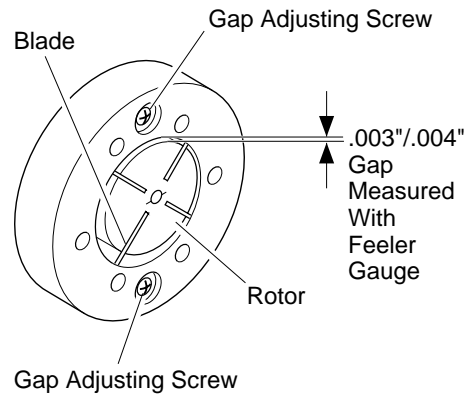

Figure 19 - Gap Adjusting Screw Locations

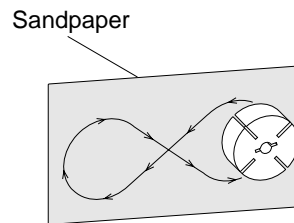

Figure 20 - Sanding Rotor

### IGNITION CONTROL ASSEMBLY (Procedure for Replacing Fuse)

**⚠ WARNING: High Voltage**

1. Unplug heater.
2. Remove side cover screws (4) using 5/16" nut-driver to expose ignition control assembly.
3. Remove fuse cover (see Figure 21).
4. Remove fuse from fuse clips.
5. Replace fuse with fuse of the same type and rating (GMA-10). Do not substitute a fuse with a higher current rating.
6. Replace fuse cover.
7. Replace side cover.

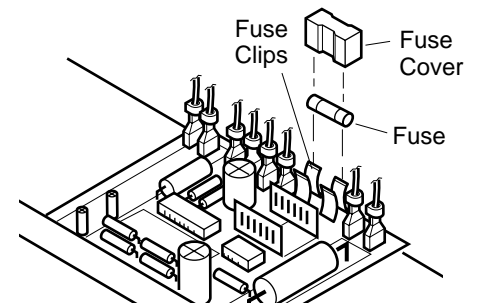

Figure 21 - Replacing Fuse

## WIRING DIAGRAM

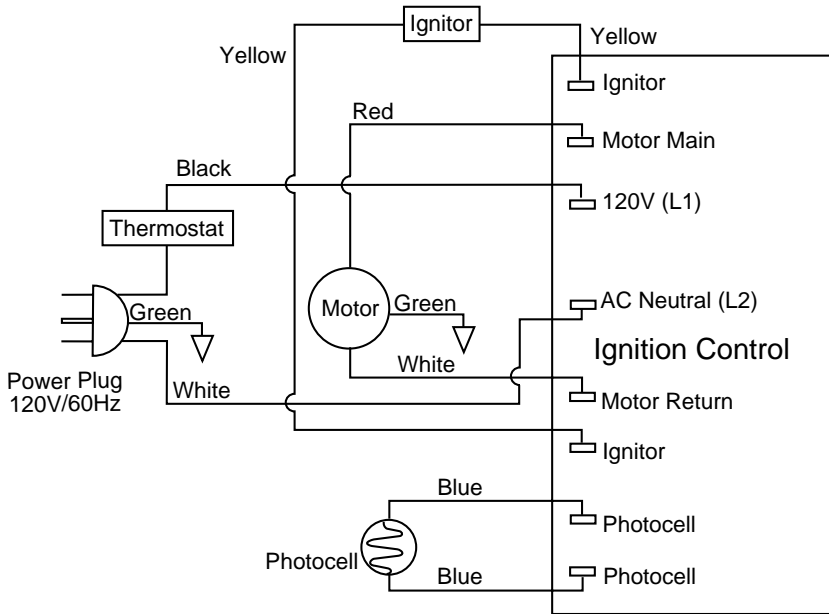

Figure 22 - Wiring Diagram

## STORING, TRANSPORTING, OR SHIPPING

**Note:** If shipping, transport companies require fuel tanks to be empty.

1. Drain fuel tank.
 

**Note:** This model has a drain plug on underside of fuel tank. Remove drain plug to drain all fuel. Be sure all fuel is removed.
2. Replace drain plug.
3. If any debris is noted in old fuel, add 1 or 2 quarts of clean kerosene to tank, stir, and drain again. This will prevent excess debris from clogging filters during future use.
4. Replace fuel cap and drain plug. Properly dispose of old and dirty fuel. Check with local automotive service stations that recycle oil.
5. If storing, store heater in dry place. Make sure storage place is free of dust and corrosive fumes.

**IMPORTANT:** Do not store kerosene over summer months for use during next heating season. Using old fuel could damage heater.

## SPECIFICATIONS

Output Rating (Btu/Hr)	110,000	115,000	150,000	155,000	165,000
Fuel	Use Only Kerosene or No. 1 Fuel Oil				
Fuel Tank Capacity (U.S. Gal.)	9.0	9.0	13.5	13.5	13.5
Fuel Consumption (Gal. Per Hr.)	0.8	.85	1.1	1.14	1.2
Pump Pressure (p.s.i.)	5.3	5.3	5.4	5.4	5.6
Electric Requirements	120 V/60 Hz				
Amperage (Normal Run)	3.6	3.6	3.6	3.6	3.6
Hot Air Output (CFM)	490	490	550	550	575
Motor RPM	3440	3440	3440	3440	3440
Motor HP	1/5	1/5	1/5	1/5	1/5
Shipping Weight					
(Approximate Pounds)	54	54	63	63	65
Heater Weight without Fuel					
(Approximate Pounds)	46	46	54	54	55

# ILLUSTRATED PARTS BREAKDOWN

**110,000, 115,000 150,000,  
155,000, AND 165,000  
BTU/HR H.S.I. SERIES**

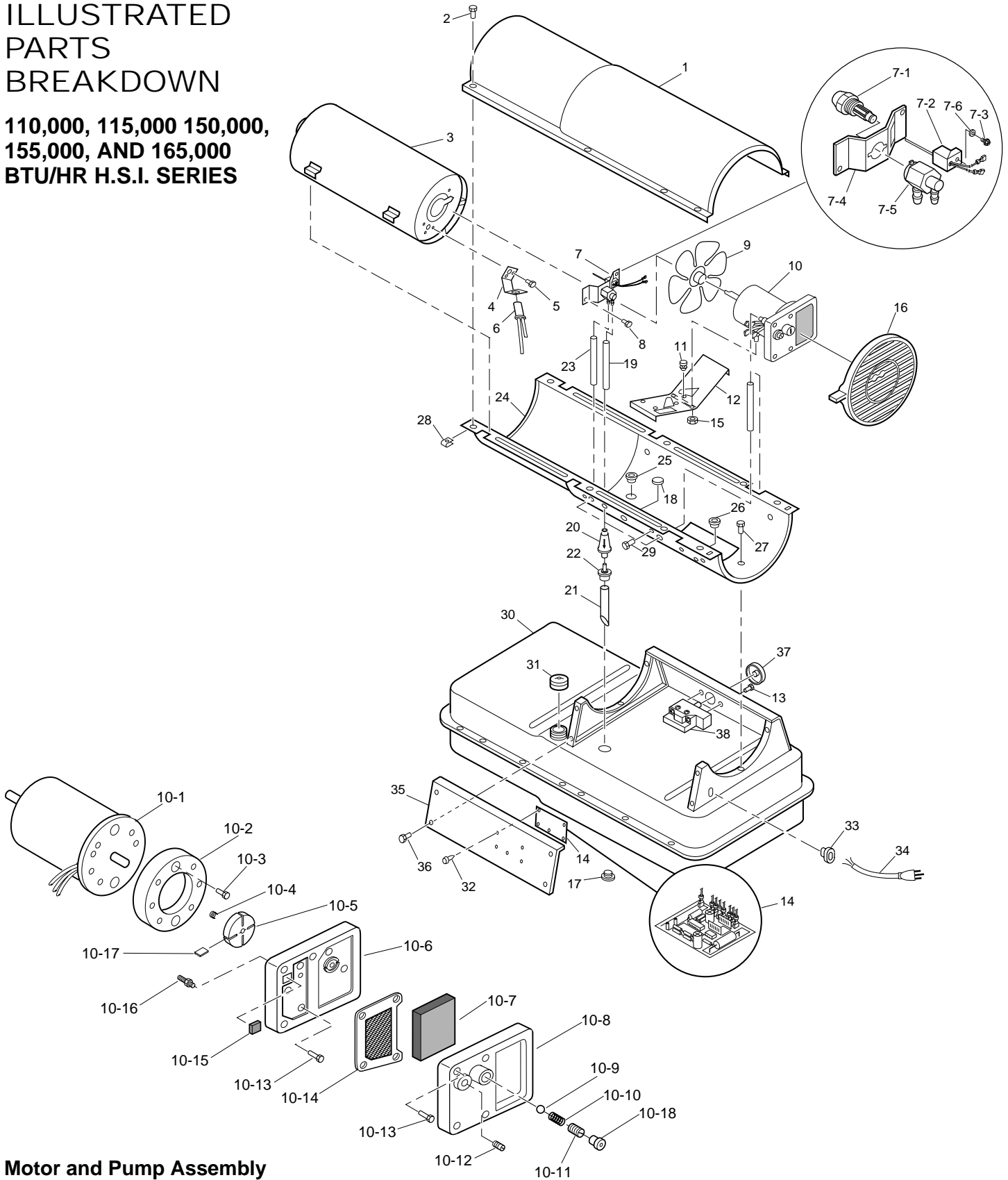

## Motor and Pump Assembly

# PARTS LIST

**110,000, 115,000 150,000,  
155,000, AND 165,000 BTU/  
HR H.S.I. SERIES**

This list contains replaceable parts used in your heater. When ordering parts, be sure to provide the correct model and serial numbers (from the model plate), then the part number and description of the desired part.

KEY NO.	PART NUMBER	DESCRIPTION	QTY.	KEY NO.	PART NUMBER	DESCRIPTION	QTY.
1	098511-66	Upper Shell (Service Part Will Be Black)	1	12	101206-01	Motor Mounting Bracket	1
2	100647-01	Screw, #10-16 x 1/2"	8	13	M10908-1	Screw, #6-32 x 1/4"	2
3	098512-54	Combustion Chamber (110/115)	1	14	104068-02	Ignition Control Assembly	1
	098512-59	Combustion Chamber (150/155)	1	15	NTC-4C	Hex Lock Nut, 1/4-20	2
	098512-60	Combustion Chamber (165)	1	16	M51114-01	Fan Guard	1
4	103971-01	Photocell Bracket (110/115)	1	17	M27417	Drain Plug (Includes "o" Ring)	1
	103154-05	Photocell Bracket (150/155/165)	1	18	099213-01	Button Plug	1
5	M10908-2	Screw, #6-32 x 3/8"	2	19	M51345-06	Fuel Line	1
6	M16656-24	Photocell Assembly	1	20	M51150-01**	Fuel Filter	1
7	***	Burner Head Assembly	1	21	M51151-01	Fuel Line Tube (110/115)	1
7-1	HA3027	Nozzle Assembly (110/115)	1	22	M51151-02	Fuel Line Tube (150/155/165)	1
	HA3028	Nozzle Assembly (150/155)	1	23	M10990-3	Rubber Bushing	1
	HA3029	Nozzle Assembly (165)	1	24	M50814-03	Airline	1
7-2	102548-03	Ignitor Kit	1		098511-236	Lower Shell (Service Part Will Be Black)	1
7-3	M10908-75	Screw	1	25	M50104-03	Bushing	1
7-4	102336-01	Nozzle Adapter Bracket	1	26	M50104-01	Bushing	1
7-5	104054-01	Nozzle Adapter	1	27	107992-01	Screw, #10-16 x 3/8"	6
7-6	103347-01	Washer	1	28	M11271-8	Clip Nut	8
8	107992-01	Screw, #10-16 x 3/8"	2	29	M10908-14	Screw, #8-32 x 3/8"	1
9	097293-01	Fan (110/115)	1	30	098513-87	Fuel Tank (110/115)	1
	102042-01	Fan (150/155/165)	1		098513-67	Fuel Tank (150/155/165)	1
10	***	Motor and Pump Assembly	1	31	097702-01	Fuel Cap (Includes Gasket)	1
10-1	102001-21	Motor	1	32	102349-01	P.C. Board Support	5
10-2	079975-02	Pump Body	1	33	M11143-1	Strain Relief Bushing	1
10-3	FHPF3-5C	Screw, #10-32 x 5/8"	2	34	098219-38	Power Cord	1
10-4	M22009**	Rotor Insert	1	35	M51077-09AA	Side Cover	1
10-5	M22456-1**	Pump Rotor	1	36	107992-01	Screw, #10-16 x 3/8"	4
10-6	M50545	Pump End Cover	1	37	104905-01	Thermostat Knob	1
10-7	M12179**	Intake Filter	1	38	097657-03	Thermostat	1
10-8	M16545	Filter End Cover	1		103814-01	Wire Tie (Not Shown) - Groups wires connected to Ignition Control Assembly	1
10-9	M8940**	Steel Ball, 1/4" Diameter	1	<b>OPTIONAL ACCESSORIES</b>			
10-10	M10993-1**	Relief Spring	1		HA1180	Air Gauge Kit	
10-11	M27694**	Adjusting Screw	1		HA2210	Fuel Tank Filter Screen	
10-12	M22997**	Plug	1		HA3004	Rotor Kit (M22456-1, M22009, M8643)	
10-13	M12461-31	Screw, #10-32 x 1"	10		HA3017	Filter Kit (M11637, M12179, M12244-1, M51150-01)	
10-14	M12244-1**	Output Filter	1		HA3020	Pump Kit (M27694, M10993-1, M22997, M8940)	
10-15	M11637**	Lint Filter	1				
10-16	104096-01	Fitting, Straight Nylon Barb	1				
10-17	M8643**	Blade	4				
10-18	105780-01	Plastic Cap	1				
11	M50631	Rubber Bumper	2				

\*\* See OPTIONAL ACCESSORIES

\*\*\* Not available as an assembly.

*Continued*

# PARTS LIST

*Continued*

## WHEELS AND HANDLE PARTS LIST

KEY NO.	PART NUMBER	PART DESCRIPTION	QTY.
1	HA2203	Handle (110/115)	2 (If Equipped)
	HA2204	Handle (150/155/165)	2 (If Equipped)
2	M12345-33	Screw, #10-24 x 1 3/4"	6 or 8
3	M12342-3	Wheel Support Frame (110/115)	1
	M12831-3	Wheel Support Frame (150/155/165)	1
4	NTC-3C	Hex Nut, #10-24	6 or 8
5	107426-01	Wheel Kit (Contains 2 Wheels and Cap Nuts)	—
6	M28526	Cap Nut	2
7	M51015-01	Axle (110/115)	1
	M16801-2	Axle (150/155/165)	1

## PART AVAILABLE - NOT SHOWN

PART NUMBER	DESCRIPTION	QTY.
100621-06	Thermostat Decal	1

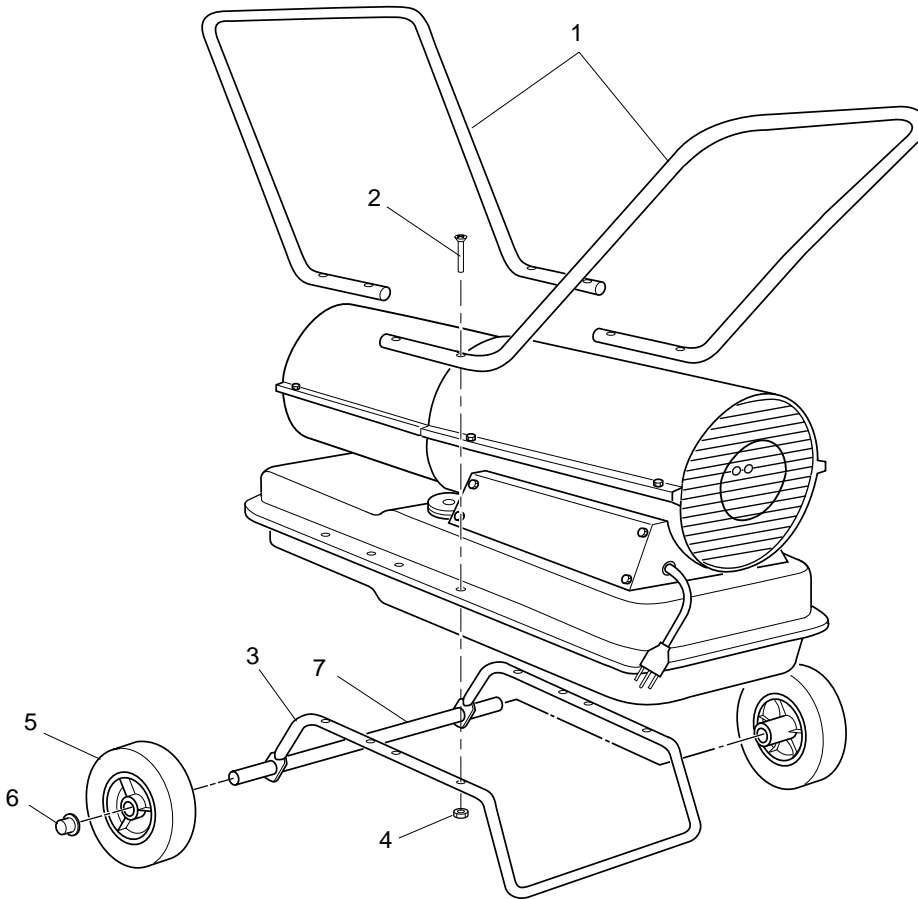

- REPLACEMENT PARTS
- TECHNICAL SERVICE
- ACCESSORIES

## REPLACEMENT PARTS

*Note:* Use only original replacement parts. This will protect your warranty coverage for parts replaced under warranty.

### PARTS UNDER WARRANTY

Contact authorized dealers of this product. If they can't supply original replacement part(s), call DESA International's Technical Service Dept. at 1-800-323-5190.

When calling DESA International, have ready

- your name
- your address
- model and serial numbers of your heater
- how heater was malfunctioning
- purchase date

Usually, we will ask you to return the defective part to the factory.

### PARTS NOT UNDER WARRANTY

Contact authorized dealers of this product. If they can't supply original replacement part(s), call DESA International at 1-800-458-2472 for referral information. Parts Centrals are listed in the Authorized Service Center booklet supplied with heater.

When calling DESA International, have ready:

- model and serial numbers of your heater
- the replacement part number

## TECHNICAL SERVICE

You may have further questions about installation, operation, or troubleshooting.

If so, contact DESA International's Technical Service Department at 1-800-323-5190.

You can also visit DESA International's technical services web site at [www.desatech.com](http://www.desatech.com).

## ACCESSORIES

Purchase accessories and parts from your nearest dealer or service center. If they can not supply these accessories or parts, either contact your nearest Parts Central or DESA International for referral information. Parts Centrals are listed in the Authorized Service Center booklet supplied with heater.

**DESA International**  
**P.O. Box 90004**  
**Bowling Green, KY**  
**42102-9004**  
**1-800-458-2472**

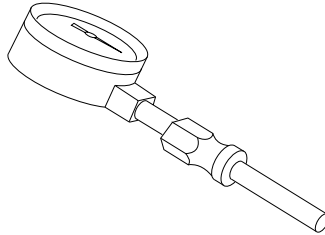

### AIR GAUGE KIT - HA1180

Special tool to check pump pressure.

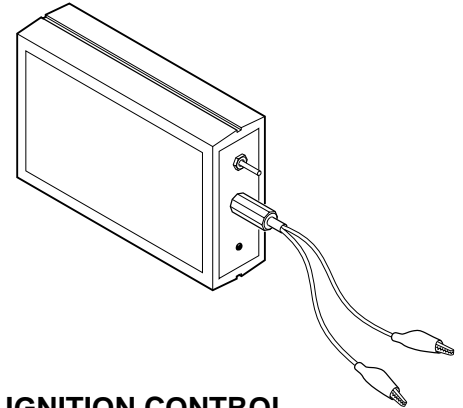

### IGNITION CONTROL ASSEMBLY/PHOTOCELL TESTER - HA1170

Special tool used to test the ignition control assembly and photocell.

# WARRANTY AND REPAIR SERVICE

## KEEP THIS WARRANTY

Model No.	_____
Serial No.	_____
Date of Purchase	_____

(To be filled in by purchaser)

### LIMITED WARRANTY

DESA International warrants this product and any parts thereof, to be free from defects in materials and workmanship for one (1) year from the date of first purchase when operated and maintained in accordance with instructions. This warranty is extended only to the original retail purchaser, when proof of purchase is provided.

This warranty covers only the cost of parts and labor required to restore the product to proper operating condition. Transportation and incidental costs associated with warranty repairs are not reimbursable under this warranty.

Warranty service is available only through authorized dealers and service centers.

This warranty does not cover defects resulting from misuse, abuse, negligence, accidents, lack of proper maintenance, normal wear, alteration, modification, tampering, contaminated fuels, repair using improper parts, or repair by anyone other than an authorized dealer or service center. Routine maintenance is the responsibility of the owner.

**THIS EXPRESS WARRANTY IS GIVEN IN LIEU OF ANY OTHER WARRANTY EITHER EXPRESSED OR IMPLIED, INCLUDING WARRANTIES OF MERCHANTABILITY AND FITNESS FOR A PARTICULAR PURPOSE.**

DESA International assumes no responsibility for indirect, incidental or consequential damages. Some states do not allow the exclusion or limitation of incidental or consequential damages or limitations or exclusions may not apply to you. This Limited Warranty gives you specific legal rights and you may also have other rights which vary from state to state.

### WARRANTY SERVICE

Should your heater require service, return it to your nearest authorized service center. Each Service Center is independently owned and operated. Proof of purchase must be presented with the heater. The heater will be inspected. A defect may be caused by faulty materials or workmanship. If so, DESA International will repair or replace the heater without charge. We reserve the right to amend these specifications at any time without notice.

### REPAIR SERVICE

Return the heater to your nearest authorized service center. Repairs not covered by the warranty will be billed at standard prices.

Illustrated parts lists can be obtained free of charge. Send a self addressed stamped envelope to the address listed below. List the heater model number and the date located in the lower right corner of this page. A service manual may be purchased from the address listed below. Send a check for \$5.00 payable to DESA International.

For more information about this warranty write:

**DESA**  
**INTERNATIONAL**  
Corporate Headquarters  
2701 Industrial Drive  
P.O. Box 90004  
Bowling Green, KY 42102-9004  
[www.desatech.com](http://www.desatech.com)

For information, write: DESA International, P.O. Box 90004  
Bowling Green, Kentucky 42102-9004 ATTN: Customer Service Department  
When writing, always include model number and serial number.



104655 01  
NOT A UPC

104655-01  
Rev. J  
03/01