

For more information, visit www.desatech.com

**Variable
100,000, 150,000, and
200,000 Btu/Hr Models**

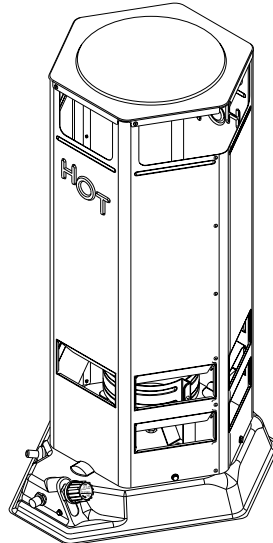

IMPORTANT: Read and understand this manual before assembling, starting, or servicing heater. Improper use of heater can cause serious injury. Keep this manual for future reference.

⚠ GENERAL HAZARD WARNING: FAILURE TO COMPLY WITH THE PRECAUTIONS AND INSTRUCTIONS PROVIDED WITH THIS HEATER, CAN RESULT IN DEATH, SERIOUS BODILY INJURY AND PROPERTY LOSS OR DAMAGE FROM HAZARDS OF FIRE, EXPLOSION, BURN, ASPHYXIATION, CARBON MONOXIDE POISONING AND/OR ELECTRICAL SHOCK.

ONLY PERSONS WHO CAN UNDERSTAND AND FOLLOW THE INSTRUCTIONS SHOULD USE OR SERVICE THIS HEATER.

IF YOU NEED ASSISTANCE OR HEATER INFORMATION SUCH AS AN INSTRUCTIONS MANUAL, LABELS, ETC. CONTACT THE MANUFACTURER.

TABLE OF CONTENTS

SAFETY INFORMATION	2	MAINTENANCE	5
PRODUCT IDENTIFICATION	3	SPECIFICATIONS	6
UNPACKING	3	REPLACEMENT PARTS	6
THEORY OF OPERATION	3	ACCESSORIES	6
PROPANE SUPPLY	3	TROUBLESHOOTING	7
INSTALLATION	4	ILLUSTRATED PARTS BREAKDOWN AND PARTS LIST	8
VENTILATION	4	OWNER'S REGISTRATION FORM	9
OPERATION	4	WARRANTY INFORMATION	Back Cover
STORAGE	5		

SAFETY INFORMATION

WARNINGS

⚠ WARNING: This product contains and/or generates chemicals known to the State of California to cause cancer or birth defects, or other reproductive harm.

⚠ WARNING: FIRE, BURN, INHALATION, AND EXPLOSION HAZARD. KEEP SOLID COMBUSTIBLES, SUCH AS BUILDING MATERIALS, PAPER OR CARDBOARD, A SAFE DISTANCE AWAY FROM THE HEATER AS RECOMMENDED BY THE INSTRUCTIONS. NEVER USE THE HEATER IN SPACES WHICH DO OR MAY CONTAIN VOLATILE OR AIRBORNE COMBUSTIBLES, OR PRODUCTS SUCH AS GASOLINE, SOLVENTS, PAINT THINNER, DUST PARTICLES OR UNKNOWN CHEMICALS.

⚠ WARNING: NOT FOR HOME OR RECREATIONAL VEHICLE USE.

The heater is designed for use as a construction heater in accordance with ANSI Z83.7/CGA 2.14. Other standards govern the use of fuel gases and heating products for specific uses. Your local authority can advise you about these. The primary purpose of construction heaters is to provide temporary heating of buildings under construction, alteration or repair. Properly used, the heater provides safe economical heating. Products of combustion are vented into the area being heated.

We cannot foresee every use which may be made of our heaters. **CHECK WITH YOUR LOCAL FIRE SAFETY AUTHORITY IF YOU HAVE QUESTIONS ABOUT HEATER USE.**

Other standards govern the use of fuel gases and heat producing products for specific uses. Your local authorities can advise you about these.

Carbon Monoxide Poisoning: Some people are more affected by carbon monoxide than others. Early signs of carbon monoxide poisoning resemble the flu, with headaches, dizziness, and/or nausea. If you have these signs, the heater may not be working properly. **Get fresh air at once!** Check for proper ventilation and have heater serviced.

Propane Gas: Propane gas is odorless. An odor-making agent is added to propane gas. The odor helps you detect a propane gas leak. However, the odor added to propane gas may fade. Propane gas may be present even though no odor exists.

Make certain you read and understand all warnings. Keep this manual for reference. It is your guide to safe and proper operation of this heater.

- Install and use heater with care. Follow all local ordinances and codes. In the absence of local ordinances and codes, refer to the *Standard for Storage and Handling of Liquefied Petroleum Gas, ANSI/NFPA 58* and the *Natural Gas Installation Code, CAN/CGA B149.2*. This instructs on the safe storage and handling of propane gases.
- This product has been approved for use in the Commonwealth of Massachusetts.
- Use only propane gas set up for vapor withdrawal.
- Provide adequate ventilation. Before using heater, provide at least a six-square-foot opening of fresh, outside air. This heater produces carbon monoxide, which is listed by the State of California as a reproductive toxin under Proposition 65.
- For indoor use only. Do not use heater outdoors.
- Keep heater away from strong drafts, wind, water spray, rain, or dripping water.
- Do not use heater in occupied dwellings or in living or sleeping quarters.
- Do not use heater in a basement or below ground level. Propane gas is heavier than air. If a leak occurs, propane gas may sink to the lowest possible level.
- Keep appliance area clear and free from combustible materials, gasoline, paint thinner, and other flammable vapors and liquids. Dust is combustible. Do not use heater in areas with high dust content.
- Minimum heater clearances from combustibles:
Sides: 3 feet, Top: 7 feet.
- Keep heater at least six feet from propane tank(s).
- Keep propane tank(s) below 100° F.
- Check heater for damage before each use. Do not use a damaged heater.
- Use only the hose and factory preset regulator provided with the heater.
- Check hose before each use of heater. If highly worn or cut, replace with hose specified by manufacturer before using heater.
- Do not alter heater. Keep heater in its original state.
- Do not use heater if altered.
- Locate heater on stable and level surface if heater is hot or operating.
- Not intended for use on finished floors.
- Never block air inlet (bottom of shell) or air outlet (around top of shell) of heater.
- Do not leave heater unattended.
- Keep children and animals away from heater.
- Never move, handle, or service a hot or operating heater. Severe burns may result. Wait 15 minutes after turning heater off.

SAFETY INFORMATION

Continued

- To prevent injury, wear gloves when handling heater.
- Never attach duct work to heater.
- Turn off propane supply to heater when not in use.
- Use only original replacement parts. This heater must use design-specific parts. Do not substitute or use generic parts. Improper replacement parts could cause serious or fatal injuries.

PRODUCT IDENTIFICATION

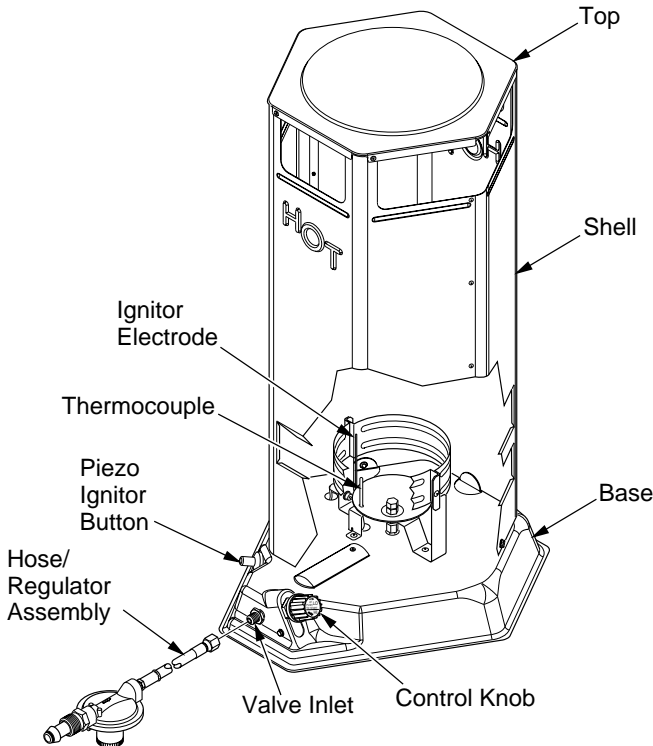

Figure 1 - Product Identification

UNPACKING

1. Remove all packing items applied to heater for shipment. Keep plastic cover caps (attached to valve inlet and hose/regulator assembly) for storage.
2. Remove all items from carton.
3. Check all items for shipping damage. If heater is damaged, promptly inform dealer where you bought heater.

THEORY OF OPERATION

The Fuel System: The hose/regulator assembly attaches to the propane gas supply. This provides fuel to the heater.

The Ignition System: The piezo ignitor lights the burner fuel supply.

The Automatic Control System: The automatic control valve shuts off the heater if the flame goes out.

PROPANE SUPPLY

You must provide propane gas and tank(s).

Use this heater only with a propane vapor withdrawal supply system. See Chapter 5 of the *Standard for Storage and Handling of Liquefied Petroleum Gas, ANSI/NFPA 58 and/or CAN/CGA B149.2*. Your local library or fire department will have this booklet.

The amount of propane gas ready for use from propane tanks varies. Two factors decide this amount.

1. The amount of liquid propane gas in tank(s)
2. The temperature of tank(s)

The chart below shows the minimum number of 100-pound tanks needed to run the heater. Connect tanks together with a manifold. Do not operate this product with any tank smaller than 100 pounds.

Average Temp. (°F) At Tank Location	Number Of Tanks
60°	2
40°	2
32°	2
20°	2
10°	3
0°	3

Less gas is vaporized at lower temperatures. Two or more 100-pound tanks or one larger tank may be needed in colder weather. Your local propane gas dealer will help you select the proper supply system.

VENTILATION

⚠ WARNING: Provide at least a 6 square foot opening of fresh, outside air while running heater. If proper fresh, outside air ventilation is not provided, carbon monoxide poisoning can occur. Provide proper fresh, outside air ventilation before running heater.

FRESH OUTSIDE AIR OPENING REQUIREMENTS

HEATER SIZE	SQ. FT. OPENING
200,000 Btu/Hr	6.0

INSTALLATION

⚠ WARNING: Review and understand the warnings in the *Safety Information* section, pages 2 and 3. They are needed to safely operate this heater. Follow all local codes when using this heater.

⚠ WARNING: Test all gas piping and connections for leaks after installation or servicing. Never use an open flame to check for a leak. Apply a mixture of liquid soap and water to all joints. Bubbles forming show a leak. Correct all leaks at once.

1. Provide propane supply system (see *Propane Supply*, page 3).
2. Connect fuel gas fitting on hose/regulator assembly to propane tank(s). Turn fuel gas fitting counterclockwise into threads on tank. Tighten firmly using a wrench. **IMPORTANT:** Tighten regulator with vent pointing down. Pointing vent down protects regulator from weather damage.
3. Connect hose to the valve inlet. Tighten firmly using a wrench. You must use the regulator supplied with heater even if propane tank has one.
4. Open propane supply valve on propane tank(s) slowly. **Note:** If not opened slowly, excess-flow check valve on propane tank may stop gas flow. If this happens, you may hear a click inside the regulator assembly, this is the check valve closing. To reset the excess-flow check valve, close propane supply valve and open it again slowly.
5. Check all connections for leaks. Apply mixture of liquid soap and water to gas joints. Bubbles forming show a leak that must be corrected.
6. Close propane supply valve.

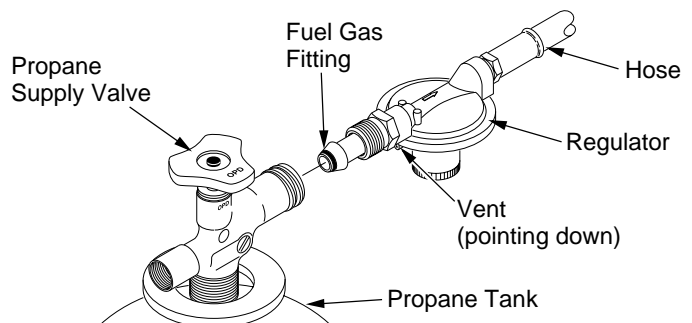

Figure 2 - Regulator With Vent Pointing Down

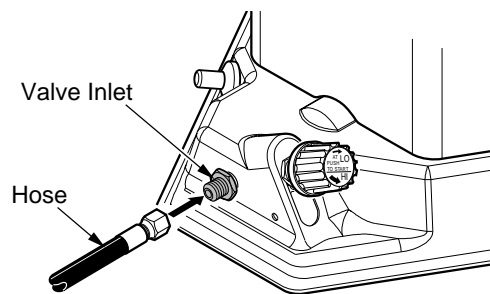

Figure 3 - Hose and Valve Inlet

OPERATION

⚠ WARNING: Review and understand the warnings in the *Safety Information* section on pages 2 and 3. They are needed to safely operate this heater. Follow all local codes when using this heater.

TO START HEATER

1. Follow all installation, ventilation, and safety information.
2. Locate heater on stable and level surface. Make sure strong drafts do not blow on heater.
3. Open propane supply valve on propane tank(s) slowly. **Note:** If not opened slowly, excess-flow check valve on propane tank may stop gas flow. If this happens, you may hear a click inside the regulator assembly, this is the check valve closing. To reset the excess-flow check valve, close propane supply valve and open it again slowly.
4. Turn control knob clockwise to the lowest position and push in (see Figure 4, page 5).
5. With the control knob pushed all the way in, press and release the piezo ignitor button (see Figure 4, page 5). Keep pressing piezo ignitor button until the burner lights. Hold control knob down for a maximum of 10 seconds while attempting ignition. If heater does not ignite, release control knob and wait 3 minutes before attempting reignition.

Note: Keep hands and face away from outlet (around top of shell) of heater while attempting to start heater.

OPERATION

Continued

6. After ignition, hold control knob down for about 30 seconds. This activates the automatic control system.
7. When burner remains lit, set heater at the desired heat level by turning the control valve counterclockwise. If burner goes out, turn off gas. Turn control knob fully clockwise to the lowest position. Check fuel supply. If adequate fuel is available, restart heater beginning at step #1.

CAUTION: Do not operate heater at extremely low input gas pressures (100% yellow flame). This may cause sooting inside heater.

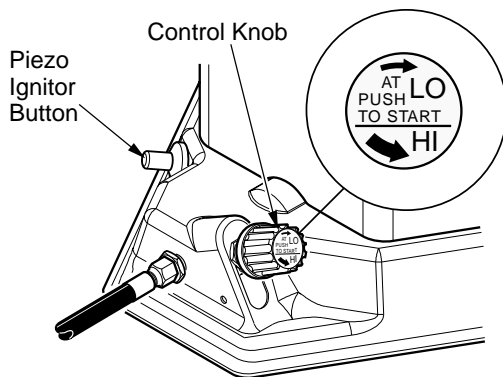

Figure 4 - Control Knob, and Piezo Ignitor Button Locations

TO STOP HEATER

1. Tightly close propane supply valve on propane tank(s). Allow heater to burn remaining fuel in hose.
2. Shut off main burner valve. Do this by turning control knob fully clockwise. Make sure you turn the knob until it stops.

TO RESTART HEATER

1. Wait five minutes after stopping heater.
2. Restart heater by following steps under *To Start Heater*, page 4.

STORAGE

CAUTION: Disconnect heater from propane supply tank(s).

1. Store propane tank(s) in safe manner. Refer to Chapter 5 of *Standard for Storage and Handling of Liquefied Petroleum Gases, ANSI/NFPA 58 and/or CAN/CGA B149.2*. Follow all local codes. Always store propane tanks outdoors.
2. Place plastic cover caps over brass fittings on valve inlet and hose/regulator assembly.
3. Store in a dry, clean, and safe place.

MAINTENANCE

WARNING: Never attempt to service heater while it is connected to propane supply, operating, or hot. Severe burns can occur.

1. Keep heater clean.
2. Inspect heater before each use. Check connections for leaks. Apply mixture of liquid soap and water to connections. Bubbles forming show a leak that must be corrected. Correct all leaks at once.
3. Inspect hose/regulator assembly before each use. If hose is highly worn or cut, replace with hose specified by manufacturer.
4. Have heater inspected yearly by a qualified service person.

SPECIFICATIONS

Rating (BTU/Hr)	High - 200,000 Medium - 150,000 Low - 100,000
Fuel	Propane Vapor Only
Fuel Consumption	Gallons/Hour - 1.09 min./2.19 max. Pounds/Hour - 4.64 min./9.28 max.
Supply Pressure To Regulator	
Maximum	200 psi
Minimum	20 psi (for input adjustment)
Manifold Pressure	High 4.6 psi, Low 5.9 psi
Minimum Temp.	-20°F (-29°C) Surrounding Air
Weight (pounds)	
Heater	16
Shipping	21
Size - L x W x H (inches)	
Heater	15 x 16 x 30
Shipping	18 x 18.6 x 31.25

REPLACEMENT PARTS

⚠ WARNING: Use only original replacement parts. This heater must use design-specific parts. Do not substitute or use generic parts. Improper replacement parts could cause serious or fatal injuries. This will also protect your warranty coverage for parts replaced under warranty.

PARTS UNDER WARRANTY

Contact authorized dealers of this product. If they can't supply original replacement part(s), either contact your nearest Parts Central or call DESA International's Technical Service Department at 1-866-672-6040. When calling DESA International, have ready

- your name
- how heater was malfunctioning
- your address
- purchase date
- model and serial numbers of your heater

In most cases, we will ask you to return the part to the factory.

PARTS NOT UNDER WARRANTY

Contact authorized dealers of this product. If they can't supply original replacement part(s), either contact your nearest Parts Central or call DESA International at 1-866-672-6040 for information. When calling DESA International, have ready

- model number of your heater
- the replacement part number

ACCESSORIES

Purchase these accessories and parts from your local dealer or service center. If your dealer or service center can not supply an accessory or part, contact your nearest Parts Central (listed in the separate Authorized Service Center booklet) or call DESA International at 1-866-672-6040 for referral information. You can also write to the address listed on the back page of this manual.

Part Number	Description
LPA1020	10' Rubber Hose with Brass Fitting U.L. listed.
LPA2005	Propane Gas Regulator U.L. listed.
LPA3005	Hose/Regulator Assembly U.L. listed.
LPA4020	Fuel Gas Connector Connects regulator to all standard propane tanks. U.L. and A.G.A. listed.

TROUBLESHOOTING

Note: For additional help, visit DESA International's technical service website at www.desatech.com.

⚠ WARNING: Never attempt to service heater while it is connected to propane supply, operating, or hot. Severe burns can occur.

SYMPTOM	POSSIBLE CAUSE	REMEDY
Burner fails to light	<ol style="list-style-type: none"> 1. Propane supply valve closed on propane tank(s) 2. Excess-flow check valve closed 3. Blockage in burner nozzle 4. Piezo ignition system not sparking 	<ol style="list-style-type: none"> 1. Open propane supply valve slowly 2. Close propane supply valve on propane tank and reopen slowly 3. Replace burner nozzle 4. Check to assure ignitor electrode gap is .130". Check wire lead for damage. Replace piezo ignitor and/or ignitor electrode as necessary
Burner lights but goes out when automatic control valve button is released	<ol style="list-style-type: none"> 1. Not enough warm-up time 2. Low gas pressure 3. Thermocouple loose or needs to be replaced 4. Automatic control valve needs to be replaced 	<ol style="list-style-type: none"> 1. Relight, hold automatic control valve button in 45 seconds 2. Check propane tank(s) for proper gas supply 3. Tighten connection or replace thermocouple 4. Replace automatic control valve
Burn rate is low	<ol style="list-style-type: none"> 1. Main burner valve not fully open 2. Plugged gas orifices 3. Low gas pressure 4. Low fuel supply 	<ol style="list-style-type: none"> 1. Fully open main burner valve by turning control knob towards HIGH position until it stops 2. Replace gas orifice 3. Check gas supply; check regulator output 4. Consult propane gas supplier

ILLUSTRATED PARTS BREAKDOWN AND PARTS LIST

MODELS TC200V RCP200V

This list contains replaceable parts used in your heater. When ordering parts, follow the instructions listed under *Replacement Parts* on page 5 of this manual.

KEY NO.	PART NO.	DESCRIPTION	QTY.
1	103925-01	Top and Shell Assembly	1
2	103923-01	Burner Ring Assembly	1
3	101263-01	Burner Plate	1
4	097162-02	Burner Nozzle	1
5	103031-02	Base	1
6	103924-01	Knob Assembly	1
7	102445-01	Piezo Ignitor	1
8	**	Thermocouple Kit	1
9	103906-01	Thermocouple Bracket	1
10	103927-01	Fuel Tube Kit	1
11	103926-01	Valve Assembly	1
12	103398-01	Ignitor Electrode	1
13	103396-01	Heat Shield	1
PARTS AVAILABLE - NOT SHOWN			
	098853-07	Tradename Decal (TC200V)	1
	098851-06	Tradename Decal (RCP200V)	1
	098831-05	Information Decal	1
	101284-02	Operation Decal	1

** Not a field replaceable part.

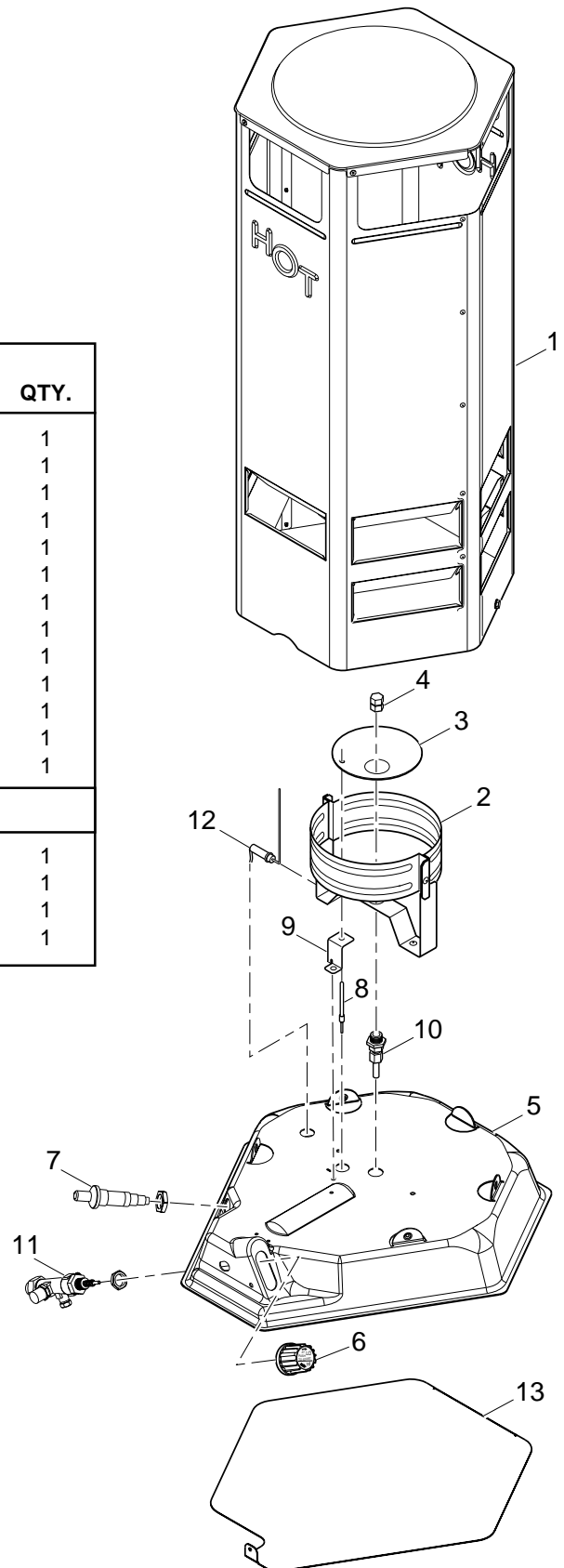

OWNER'S REGISTRATION FORM

Complete registration form and mail or complete on-line registration at www.desatech.com within 30 days after purchase.

Brand: _____ (Reddy Heater, Master, Remington, etc.)
 Model: _____ (R60, HD15, etc.)
 Date Purchased: _____ Note: Keep receipt for warranty verification.
 Serial Number: _____ 7 or 9 digit number located on product or identification tag.
 First Name: _____ Last Name: _____
 Address: _____
 City: _____ State: _____ Zip: _____ Country: _____
 Phone: (____) _____ - _____ E-Mail: _____

Please answer the following questions to register your product with DESA International:

1. Who will heater be used by? Individual Business
2. Will you use your heater in more than one location? Yes No
3. Where will the product be used? (You may select more than one.) Workshop Barn Residential Construction
 Commercial Construction Garage Factory Recreation Warehouse Utility Shed/Outbuilding
 Other _____ (Specify)
4. Cost of product (excluding sales tax)? \$ _____
5. Maintenance/service work will be performed by: Self Service Center Other _____
6. If you bought this product yourself, did you plan to purchase this type of product before going into the store? Yes No
7. Type of store where product was purchased? Hardware Propane Dealer Natural Gas/Utility Co. Home Center or Builder's Supply
 Farm/Ag. Supply Auto Parts Warehouse Club Industrial/Contractor Supply Rental Store
 Discount Store HVAC Dealer Other _____
8. What is your primary source of heat? Propane (LP Gas) Natural Gas Kerosene Diesel Electric Other _____
9. What motivated you to buy this product? Sudden Cold Weather Replace Older Model D.I.Y. Home Project Emergency Back-Up Heat
 Heater on Sale Construction Project Hard to Heat Location Other _____
10. How did you learn about this product brand? Advertisement Relative or Friend Co-Worker Store Representative
 Store Display Previously Owned a Heater Other _____ (Specify)
11. What other brands did you consider? None Master Remington All-Pro Dayton Universal Mr. Heater L.B. White Tradesman
 John Deere Dyna-Glo Dura-Heat Paulin Coleman Vogelzang American Other _____
12. Who selected the product? Male Female Both
13. Level of Education of Purchaser: High School Vocation/Technical School Some College Completed College Graduate School
14. Age of Purchaser: Under 20 20 - 29 30 - 39 40 - 49 50 - 59 60 or Over
15. Buyer's total annual household income: Under \$19,999 \$20,000 to \$34,999 \$35,000 to \$49,999
 \$50,000 to \$74,999 \$75,000 to \$99,999 \$100,000 and Over
16. What is the population of your area? Under 10,000 10,000 to 25,000 25,000 to 50,000 50,000 to 100,000
 100,000 to 250,000 Over 250,000

17. Store where product was purchased:
 Name: _____ City: _____ State: _____

18. In choosing this product, how important were the following:
- | | Not | Somewhat | Very | | Not | Somewhat | Very |
|-------------------------------|-----------------------|-----------------------|-----------------------|----------------------------------|-----------------------|-----------------------|-----------------------|
| Availability | <input type="radio"/> | <input type="radio"/> | <input type="radio"/> | Size | <input type="radio"/> | <input type="radio"/> | <input type="radio"/> |
| Price | <input type="radio"/> | <input type="radio"/> | <input type="radio"/> | Prior Brand Experience | <input type="radio"/> | <input type="radio"/> | <input type="radio"/> |
| Brand Name | <input type="radio"/> | <input type="radio"/> | <input type="radio"/> | Built-In Thermostat | <input type="radio"/> | <input type="radio"/> | <input type="radio"/> |
| Overall Quality | <input type="radio"/> | <input type="radio"/> | <input type="radio"/> | Ease of Operation | <input type="radio"/> | <input type="radio"/> | <input type="radio"/> |
| Heat Output (Btu/Hr Rating) | <input type="radio"/> | <input type="radio"/> | <input type="radio"/> | Special Features | <input type="radio"/> | <input type="radio"/> | <input type="radio"/> |
| Variable Heat Output (Btu/Hr) | <input type="radio"/> | <input type="radio"/> | <input type="radio"/> | Salesperson's Recommendation | <input type="radio"/> | <input type="radio"/> | <input type="radio"/> |
| Made in USA | <input type="radio"/> | <input type="radio"/> | <input type="radio"/> | Friend/Relative's Recommendation | <input type="radio"/> | <input type="radio"/> | <input type="radio"/> |
| Warranty | <input type="radio"/> | <input type="radio"/> | <input type="radio"/> | Portability | <input type="radio"/> | <input type="radio"/> | <input type="radio"/> |
| Local Service | <input type="radio"/> | <input type="radio"/> | <input type="radio"/> | Quiet Operation | <input type="radio"/> | <input type="radio"/> | <input type="radio"/> |
| Value for Price | <input type="radio"/> | <input type="radio"/> | <input type="radio"/> | | | | |

19. This question will allow us to better understand the demographic profile of our customers. Which of the following best describes you? (not required)
 African American Asian American Mexican Puerto Rican Cuban Other Hispanic White Other _____

TAPE

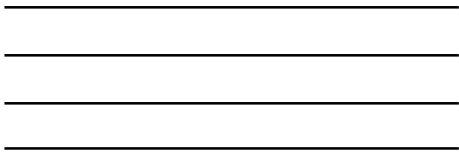

Postage
Required

DESA[™]
INTERNATIONAL
2701 Industrial Drive
P.O. Box 90004
Bowling Green, KY 42102-9004

TAPE

OTHER OUTDOOR HEATING PRODUCTS

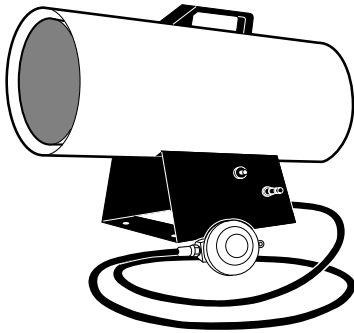

PROPANE/LP FORCED AIR HEATERS

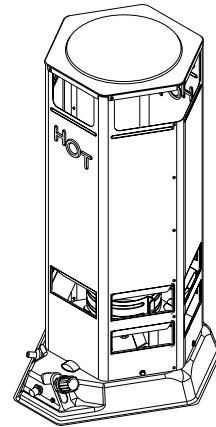

PROPANE/LP CONVECTION HEATERS

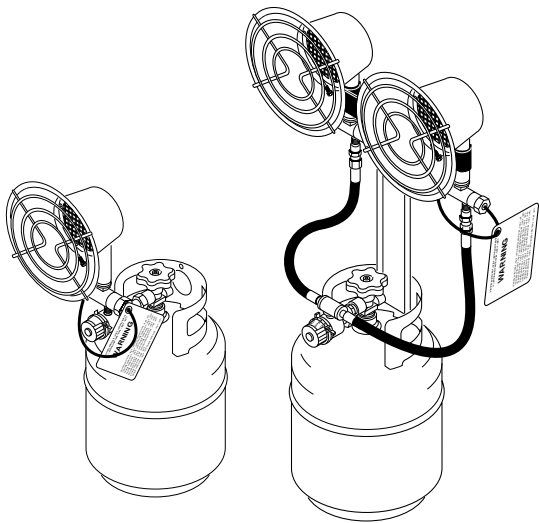

PROPANE/LP TANK TOP HEATERS

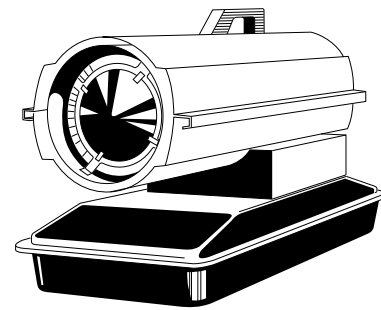

PORTABLE KEROSENE/DIESEL FORCED AIR HEATERS

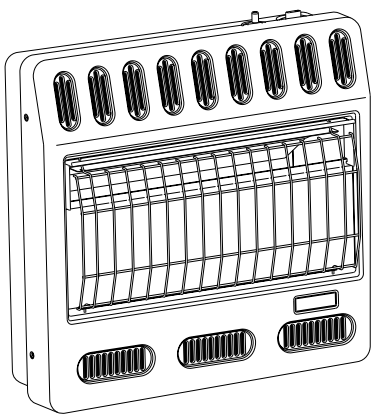

PROPANE/LP AND NATURAL GAS GARAGE HEATERS

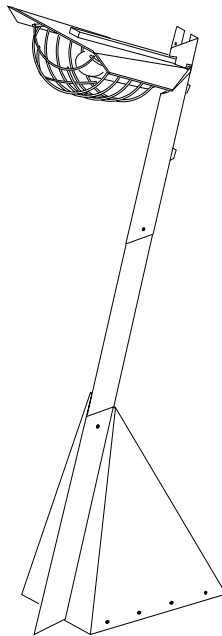

PROPANE/LP PATIO HEATERS



PROPANE/LP AND NATURAL GAS CHIMENEAS

WARRANTY AND REPAIR SERVICE

KEEP THIS WARRANTY

LIMITED WARRANTY

DESA International warrants this product and any parts thereof, to be free from defects in materials and workmanship for one (1) year from the date of first purchase when operated and maintained in accordance with instructions. This warranty is extended only to the original retail purchaser, when proof of purchase is provided.

This warranty covers only the cost of parts and labor required to restore the product to proper operating condition. Transportation and incidental costs associated with warranty repairs are not reimbursable under this warranty.

Warranty service is available only through authorized dealers and service centers.

This warranty does not cover defects resulting from misuse, abuse, negligence, accidents, lack of proper maintenance, normal wear, alteration, modification, tampering, contaminated fuels, repair using improper parts, or repair by anyone other than an authorized dealer or service center. Routine maintenance is the responsibility of the owner.

THIS EXPRESS WARRANTY IS GIVEN IN LIEU OF ANY OTHER WARRANTY EITHER EXPRESSED OR IMPLIED, INCLUDING WARRANTIES OR MERCHANTABILITY AND FITNESS FOR A PARTICULAR PURPOSE.

DESA International assumes no responsibility for indirect, incidental or consequential damages. Some states do not allow the exclusion or limitation of incidental or consequential damages, or limitations or exclusions may not apply to you. This Limited Warranty gives you specific legal rights and you may also have other rights which vary from state to state.

This warranty does not cover discoloration due to operation of heater. We reserve the right to amend these specifications at any time without notice. The only warranty applicable is our standard written warranty. We make no other warranty, expressed or implied.

WARRANTY SERVICE

Should your heater require service, return it to your nearest authorized service center. Proof of purchase must be presented with the heater. The heater will be inspected. A defect may be caused by faulty materials or workmanship. If so, DESA International will repair or replace the heater without charge.

REPAIR SERVICE

Return your heater to your nearest authorized service center. Repairs not covered by the warranty will be billed at standard prices. Each Service Center is independently owned and operated. We reserve the right to amend these specifications at any time without notice.

For information, write: DESA International, P.O. Box 90004
Bowling Green, Kentucky 42102-9004 ATTN: Customer Service Department
When writing, always include model number and serial number.

Model _____

Serial No. _____

Date of Purchase _____

DESATM
INTERNATIONAL
2701 Industrial Drive
P.O. Box 90004
Bowling Green, KY 42102-9004

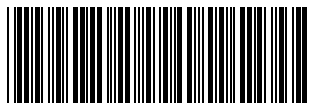

103386 01

NOT A UPC

103386-01
Rev. G
11/02