

PORTABLE FORCED AIR HEATER

(WITH BUILT-IN THERMOSTAT)

OWNER'S MANUAL

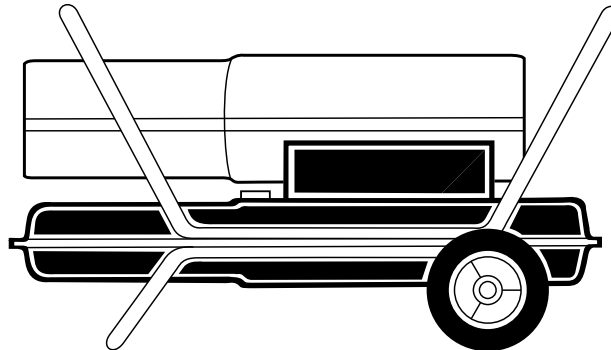

Heater Sizes: 70,000 and 150,000 BTU/Hr

IMPORTANT

Read and understand this manual before assembling, starting, or servicing heater. Improper use of heater can cause serious injury. Keep this manual for future reference.



CONTENTS

SECTION	PAGE
Safety Information	2
Product Identification	4
Unpacking	5
Assembly	5
Theory of Operation	6
Fuels	6
Ventilation	7
Operation	7
Storage	8
Preventative Maintenance Schedule	8
Troubleshooting	9
Service Procedures	10
Upper Shell Removal	10
Fan	10
Air Output, Air Intake, and Lint Filters	10
Pump Pressure Adjustment	11
Fuel Filter	11
Spark Plug	12
Nozzle	12
Pump Rotor	13
Specifications	14
Wiring Diagram	14
Maintenance Kits	15
Accessories	15
Warranty and Repair Service	Back Cover

SAFETY INFORMATION

WARNINGS

IMPORTANT: Read this Owner's Manual carefully and completely before trying to assemble, operate, or service this heater. Improper use of this heater can cause serious injury or death from burns, fire, explosion, electrical shock, and carbon monoxide poisoning.

DANGER

Carbon monoxide poisoning may lead to death!

Carbon Monoxide Poisoning: Early signs of carbon monoxide poisoning resemble the flu, with headaches, dizziness, and/or nausea. If you have these signs, the heater may not be working properly. **Get fresh air at once!** Have heater serviced. Some people are more affected by carbon monoxide than others. These include pregnant women, persons with heart or lung disease or anemia, those under the influence of alcohol, and those at high altitudes.

Make certain you read and understand all Warnings. Keep this manual for reference. It is your guide to safe and proper operation of this heater.

SAFETY INFORMATION

- Use only kerosene or No. 1 fuel oil to avoid risk of fire or explosion. Never use gasoline, naphtha, paint thinners, alcohol, or other highly flammable fuels.
- Fueling
 - a) Personnel involved with fueling shall be qualified and thoroughly familiar with the manufacturer's instructions and applicable federal, state, and local regulations regarding the safe fueling of heating units.
 - b) Only the type of fuel specified on the heater's data plate shall be used.
 - c) All flame, including the pilot light, if any, shall be extinguished and the heater allowed to cool, prior to fueling.
 - d) During fueling, all fuel lines and fuel-line connections shall be inspected for leaks. Any leaks shall be repaired prior to returning the heater to service.
 - e) At no time shall more than one day's supply of heater fuel be stored inside a building in the vicinity of the heater. Bulk fuel storage shall be outside the structure.
 - f) All fuel storage shall be located a minimum of 25 feet from heaters, torches, welding equipment, and similar sources of ignition (exception: the fuel reservoir integral with the heater unit).
 - g) Whenever possible, fuel storage shall be confined to areas where floor penetrations do not permit fuel to drip onto or be ignited by a fire at lower elevation.
 - h) Fuel storage shall be in accordance with the federal, state, or local authority having jurisdiction.
- Never use heater where gasoline, paint thinner, or other highly flammable vapors are present.
- Follow all local ordinances and codes when using heater.
- Heaters used in the vicinity of tarpaulins, canvas, or similar enclosure materials shall be located a safe distance from such materials. The recommended minimum safe distance is 10 feet. It is further recommended that these enclosure materials be of a fire retardant nature. These enclosure materials shall be securely fastened to prevent them from igniting or from upsetting the heater due to wind action.
- Use only in well vented areas. Before using heater, provide at least a three-square-foot opening of fresh, outside air for each 100,000 BTU/Hr of rating. This heater produces carbon monoxide, which is listed by the State of California as a reproductive toxin under Proposition 65.
- Use only in places free of flammable vapors or high dust content.
- Use only with the electrical voltage and frequency specified on model plate.
- Use only a three-prong, grounded extension cord.
- Minimum heater clearances from combustibles:
Outlet: 8 Ft. Sides: 4 Ft. Top: 4 Ft. Rear: 4 Ft.
- Locate heater on a stable and level surface while hot or running or a fire may occur.
- When moving or storing heater, keep heater in a level position or fuel spillage may occur.
- Keep children and animals away from heater.
- Unplug heater when not in use.
- This heater is equipped with a thermostat. Heater may start at anytime.
- Never use heater in living or sleeping areas.
- Never block air inlet (rear) or air outlet (front) of heater.
- Never move, handle, refuel, or service a hot, operating, or plugged-in heater.
- Never attach duct work to front or rear of heater.

PRODUCT IDENTIFICATION

70,000 BTU/Hr Model

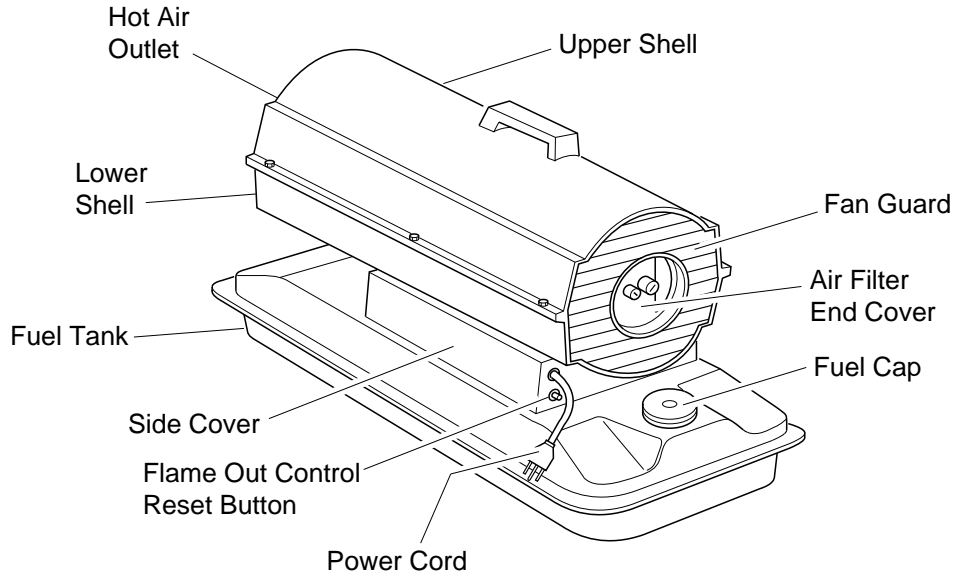

150,000 BTU/Hr Model

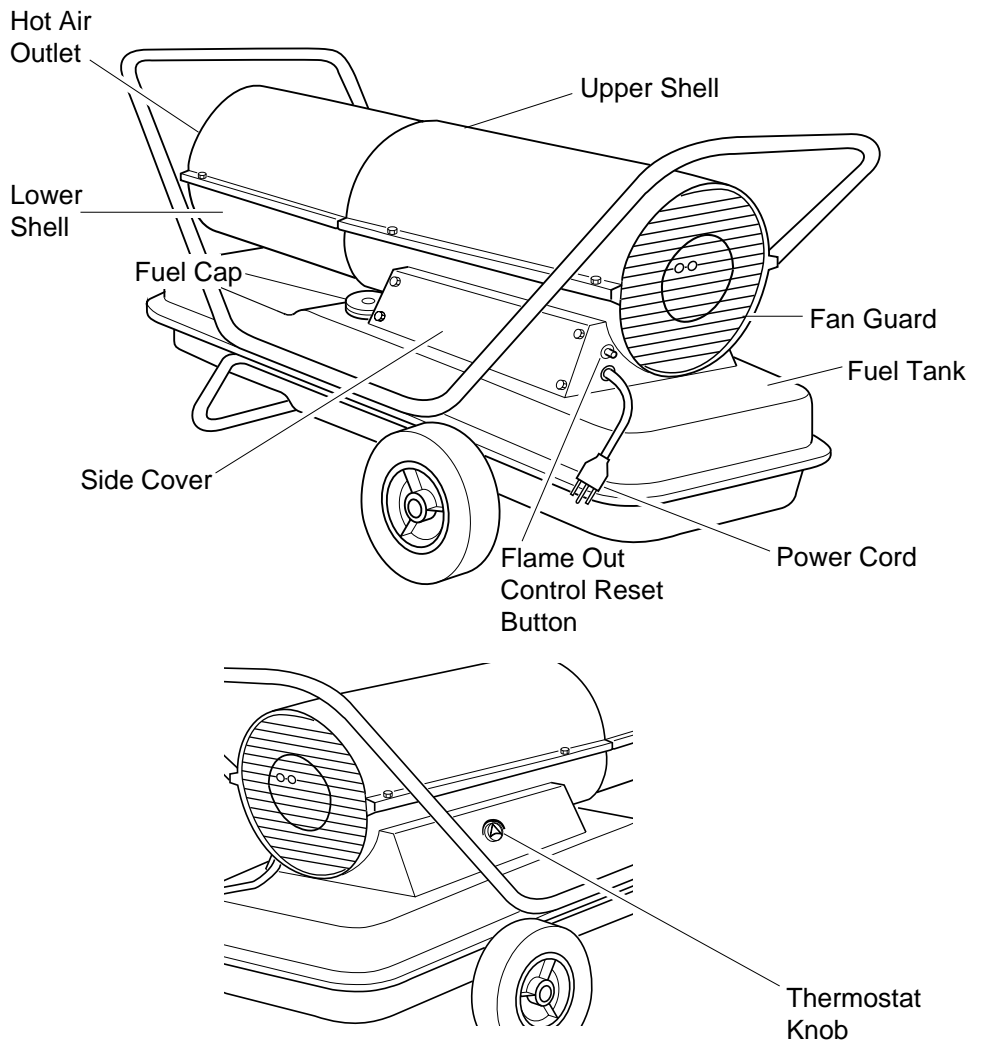

Figure 1 - 70,000 and 150,000 BTU/Hr Models

UNPACKING

1. Remove all packing items applied to heater for shipment.
2. Remove all items from carton.
3. Check items for shipping damage. If heater is damaged, promptly inform dealer where you bought heater.

ASSEMBLY

The 150,000 BTU/Hr model is furnished with wheels and handles. Wheels, handles, and the mounting hardware are found in the shipping carton.

Tools Needed

- Medium Phillips Screwdriver
- 3/8" Open or Adjustable Wrench
- Hammer

1. Slide axle through wheel support frame. Install wheels on axle.
IMPORTANT: When installing wheels, point extended hub of wheels toward wheel support frame (see Figure 2).
2. Place cap nuts on axle ends. Gently tap with hammer to secure.
3. Place heater on wheel support frame. Make sure air inlet end (rear) of heater is over wheels. Line up holes on fuel tank flange with holes on wheel support frame.
4. Place front handle and rear handle on top of fuel tank flange. Insert screws through handles, fuel tank flange, and wheel support frame. Attach nut finger tight after each screw is inserted.
5. After all screws are inserted, tighten nuts firmly.

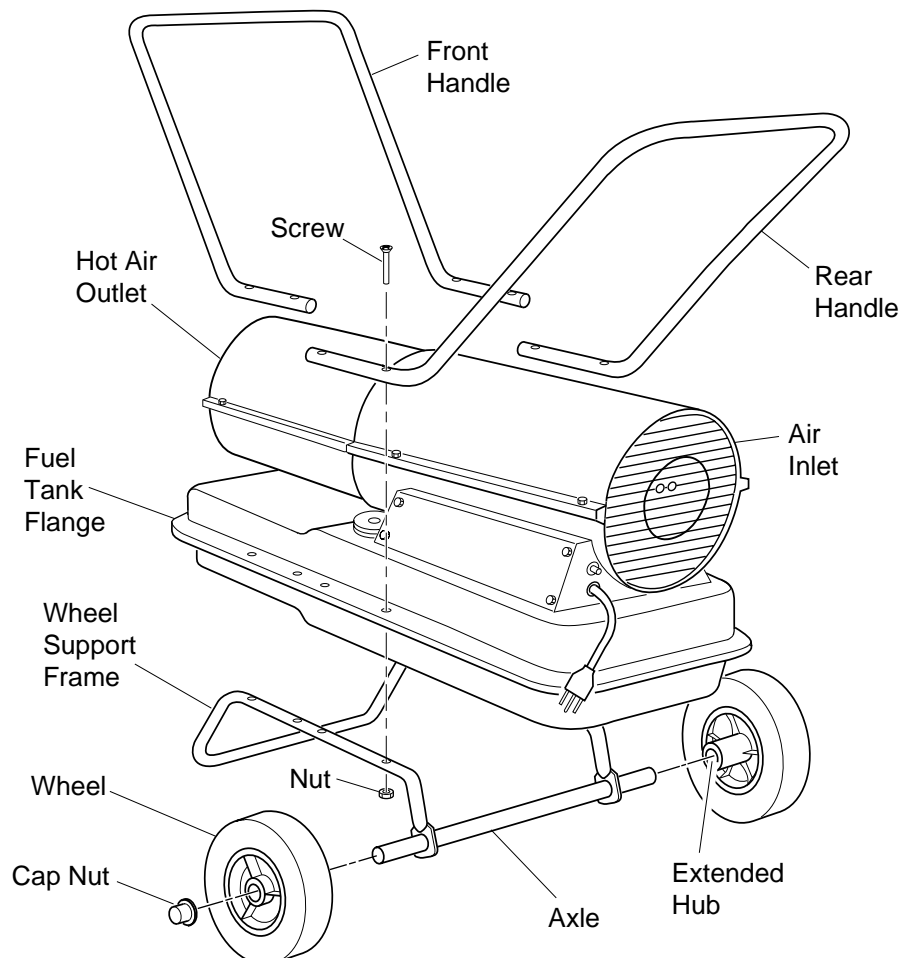

Figure 2 - Wheel and Handle Assembly

THEORY OF OPERATION

The Fuel System: The air pump forces air through the air line. The air is then pushed through the burner head nozzle. This air causes fuel to lift from the tank. A fine mist of fuel is sprayed into the combustion chamber.

The Air System: The motor turns the fan. The fan pushes air into and around the combustion chamber. This air is heated and provides a stream of clean, hot air.

The Ignition System: The electronic ignitor sends voltage to the spark plug. The spark plug ignites the fuel and air mixture.

The Flame Out Control System: This system causes the heater to shut down if the flame goes out.

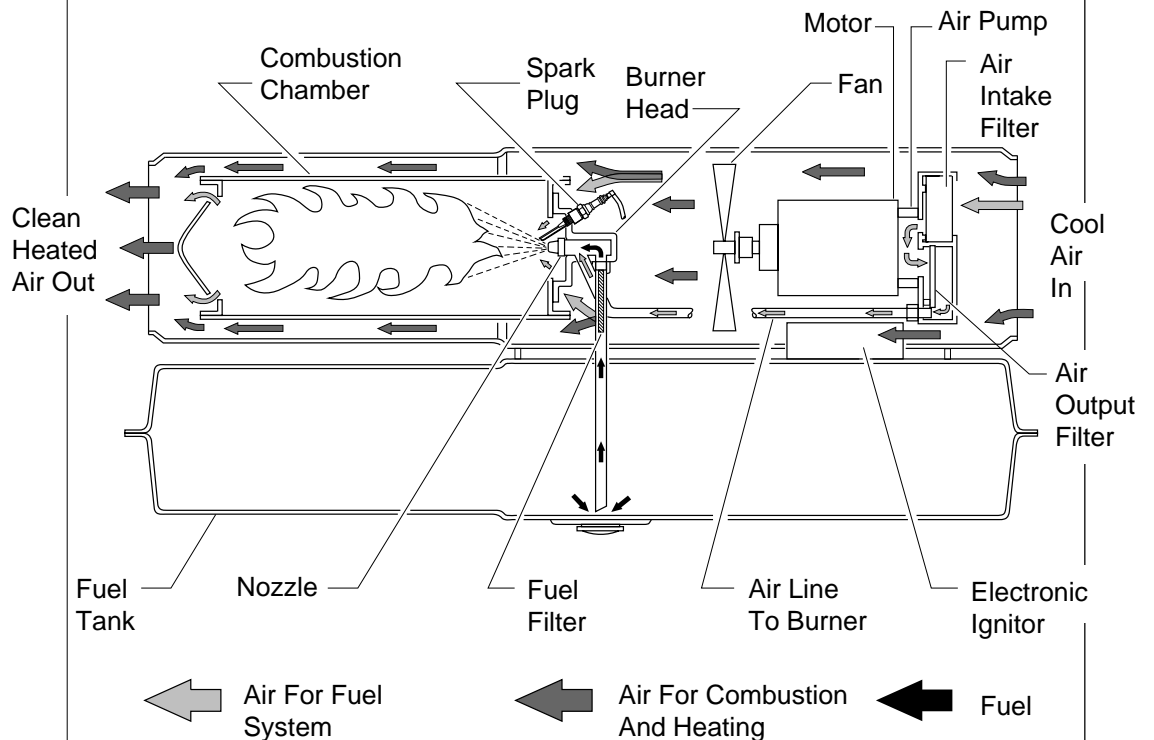

Figure 3 - Cross Section Operational View

FUELS

! WARNING

Use only kerosene or No. 1 fuel oil to avoid risk of fire or explosion. Never use gasoline, naphtha, paint thinners, alcohol, or other highly flammable fuels.

Do not use heavy fuels such as No. 2 fuel oil or No. 2 Diesel. Using heavy fuels will result in:

- clogged fuel filter and nozzle
- carbon build up on spark plug
- the need of non-toxic anti-icer in fuel during very cold weather

IMPORTANT: Use a KEROSENE ONLY storage container. Be sure storage container is clean. Foreign matter such as rust, dirt, or water will cause the flame out control to shut down heater. Foreign matter may also require you to clean fuel system often.

VENTILATION

WARNING

Follow the minimum fresh, outside air ventilation requirements. If proper fresh, outside air ventilation is not provided, carbon monoxide poisoning can occur. Provide proper fresh, outside air ventilation before running heater.

Provide at least a three-square-foot opening of fresh, outside air for each 100,000 BTU/Hr rating. Provide extra fresh air if more heaters are being used. *Example:* A 150,000 BTU/Hr heater requires one of the following:

- a two-car garage door raised six inches
- a single-car garage door raised nine inches
- two, thirty-inch windows raised twelve inches

OPERATION

WARNING

Review and understand the warnings in the Safety Information Section. They are needed to safely operate this heater. Follow all local codes when using this heater.

To Start Heater

1. Follow all ventilation and safety information.
2. Fill fuel tank with kerosene or No. 1 fuel oil.
3. Attach fuel cap.
4. Plug power cord of heater into three-prong, grounded extension cord. Extension cord must be at least six feet long.

Extension Cord Wire Size Requirements

6 to 10 feet long, use 18 AWG rated cord

11 to 100 feet long, use 16 AWG rated cord

101 to 200 feet long, use 14 AWG rated cord

5. Plug extension cord into standard 120 volt/60 hertz, three-hole, grounded outlet. Adjust thermostat to desired setting. If heater does not start, thermostat setting may be too low. Turn thermostat knob to higher position to start heater. If thermostat is in HIGH position and heater still will not start, push in flame-out control reset button (see Figure 4).

Flame- Out Control
Reset Button

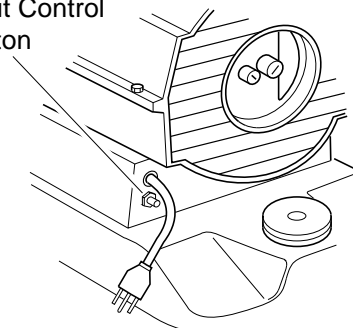

70,000 BTU/Hr Model

Flame- Out Control
Reset Button

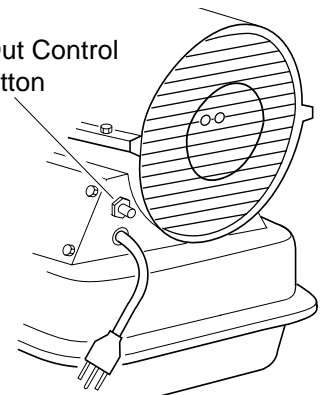

150,000 BTU/Hr Model

Figure 4 - Flame Out Control Reset Button

Continued

OPERATION

Continued

To Stop Heater

1. Unplug extension cord from outlet.

To Restart Heater

1. Wait 2 minutes after stopping heater.
2. Repeat steps under *To Start Heater*, page 7.

STORAGE

1. Drain fuel tank.
Note: Some models have drain plug on underside of fuel tank. If so, remove drain plug to drain all fuel. If heater does not have drain plug, drain fuel through fuel cap opening. Be sure all fuel is removed.
2. Replace drain plug if used.
3. Add one gallon of clean kerosene to fuel tank.
4. Attach fuel cap.
5. Move heater forwards and backwards to stir fuel.
6. Remove fuel cap or drain plug and drain fuel tank. Be sure all fuel is removed.
7. Replace fuel cap or drain plug. Properly dispose of old and dirty fuel.
8. Store heater in dry place. Make sure storage place is free of dust and corrosive fumes.

IMPORTANT: Do not store kerosene over summer months for use during next heating season. Using old fuel could damage heater.



WARNING

Never service heater while it is plugged in, operating, or hot. Severe burns and electrical shock can occur.

PREVENTATIVE MAINTENANCE SCHEDULE

Item	How Often	How To
Fuel tank	Flush every 150-200 hours of operation or as needed.	See <i>Storage</i> above.
Air output and lint filters	Replace every 500 hours of operation or once a year.	See <i>Air Output, Air Intake, and Lint Filters</i> , page 10.
Air intake filter	Wash and dry with soap and water every 500 hours of operation or replace as needed.	See <i>Air Output, Air Intake, and Lint Filters</i> , page 10.
Fuel filter	Clean twice a heating season or replace as needed.	See <i>Fuel Filter</i> , page 11.
Spark plug	Clean and regap every 600 hours operation or replace as needed.	See <i>Spark Plug</i> , page 12.
Fan blades	Clean each season or as needed.	See <i>Fan</i> , page 10.
Motor	Not required/permanently lubricated	

TROUBLE-SHOOTING

WARNING

Never service heater while it is plugged in, operating, or hot. Severe burns and electrical shock can occur.

<u>OBSERVED FAULT</u>	<u>POSSIBLE CAUSE</u>	<u>REMEDY</u>
Heater ignites, but flame out control shuts off heater after a short period of time.	Wrong pump pressure.	See <i>Pump Pressure Adjustment</i> , page 11.
	Dirty air output, air intake and lint filters.	See <i>Air Output, Air Intake and Lint Filters</i> , page 10.
	Dirty fuel filter.	See <i>Fuel Filter</i> , page 11.
	Dirt in nozzle.	See <i>Nozzle</i> , page 12.
	Dirty photocell lens.	Clean photocell lens.
	Bad flame out control.	Replace flame out control.
Heater will not ignite, but motor runs for a short period of time.	Wrong pump pressure.	See <i>Pump Pressure Adjustment</i> , page 11.
	Carbon deposits on spark plug and/or improper gap.	See <i>Spark Plug</i> , page 12.
	Dirty fuel filter.	See <i>Fuel Filter</i> , page 11.
	Dirt in nozzle.	See <i>Nozzle</i> , page 12.
	Water in fuel tank.	Drain and flush fuel tank with clean kerosene. See <i>Storage</i> , page 8.
 WARNING: High voltage!		
Motor does not start when heater is plugged in, fan rotates slowly or does not turn.	Electronic ignitor not grounded.	Make sure electronic ignitor mounting is tight.
	Bad electronic ignitor.	Replace electronic ignitor.
	Thermostat setting is too low.	Turn thermostat knob to a higher setting.
	Flame out control not reset.	Press flame out control reset button.
	Solid state relay not allowed to reset.	Wait two minutes before trying to restart heater.
	Binding pump rotor.	If fan is hard to turn, see <i>Pump Rotor</i> , page 13.

SERVICE PROCEDURES

Upper Shell Removal

1. Remove screws along each side of heater using 5/16" nut-driver. These screws attach upper and lower shells together.
2. Lift upper shell off.
3. Remove fan guard.

Fan

IMPORTANT: Remove fan from motor shaft before removing motor from heater. The weight of the motor resting on the fan could damage the fan pitch.

1. Remove upper shell (see above).
2. Use 1/8" allen wrench to loosen set-screw which holds fan to motor shaft.
3. Slip fan off motor shaft.
4. Clean fan using soft cloth moistened with kerosene or solvent.
5. Dry fan thoroughly.
6. (70,000 BTU/Hr Model) Replace fan on motor shaft. Place fan hub flush with end of motor shaft (see Figure 6).
- (150,000 BTU/Hr Model) Replace fan on motor shaft. Make sure set screw is touching back of flat surface on motor shaft (see Figure 6).
7. Place setscrew on flat of shaft. Tighten setscrew firmly (40-50 inch-pounds).
8. Replace fan guard and upper shell.

Air Output, Air Intake, and Lint Filters

1. Remove upper shell (see above).
2. Remove filter end cover screws using 5/16" nut-driver.
3. Remove filter end cover.
4. Replace air output and lint filters.
5. Wash or replace air intake filter (see *Preventative Maintenance Schedule*, page 8).
6. Replace filter end cover.
7. Replace fan guard and upper shell.

IMPORTANT: Do not oil filters.

WARNING

Never service heater while it is plugged in, operating, or hot. Severe burns and electrical shock can occur.

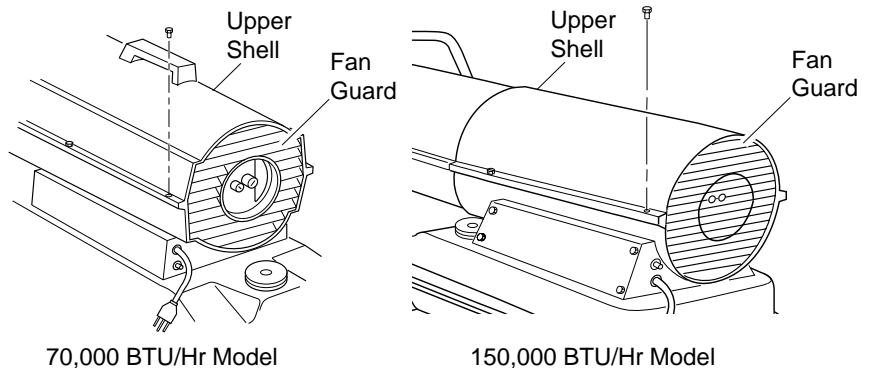

Figure 5 - Upper Shell Removal

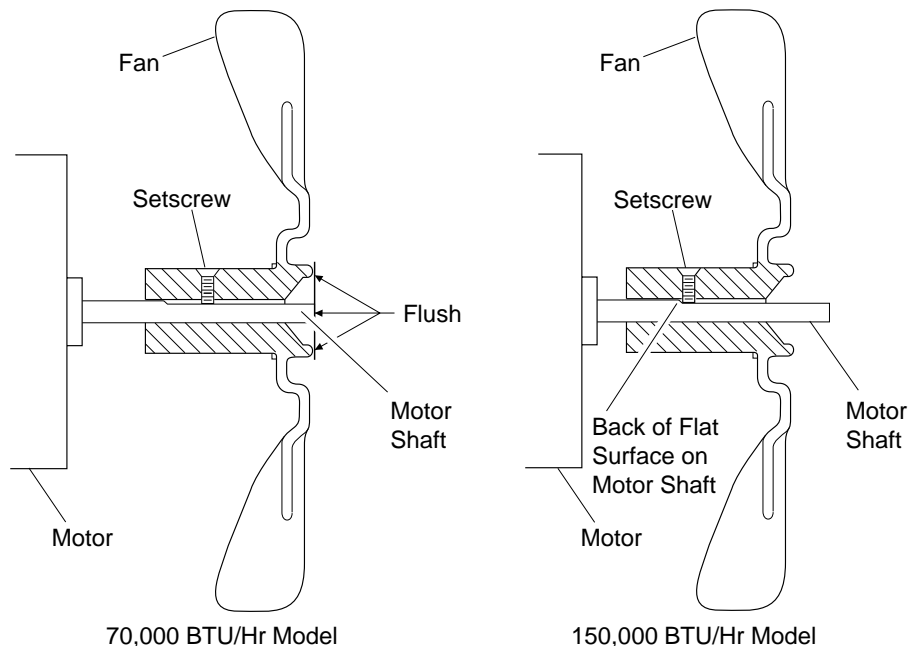

Figure 6 - Fan Cross Section

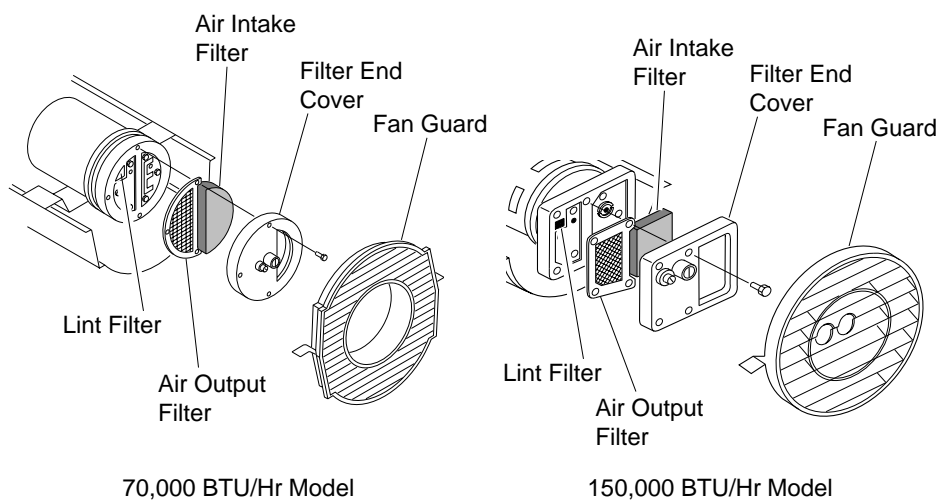

Figure 7 - Air Output, Air Intake, and Lint Filters

Pump Pressure Adjustment

1. Remove pressure gauge plug from filter end cover.
2. Install accessory pressure gauge (part number HA1180).
3. Start heater (see *Operation*, page 7). Allow motor to reach full speed.
4. Adjust pressure. Turn relief valve to right to increase pressure. Turn relief valve to left to decrease pressure.

Correct Pump Pressure

70,000 BTU/Hr Model: 4.0 PSI
150,000 BTU/Hr Model: 5.0 PSI

5. Remove pressure gauge. Replace pressure gauge plug in filter end cover.

Fuel Filter

1. Remove side cover screws using 5/16" nut-driver.
2. Remove side cover.
3. Pull upper fuel line off fuel filter neck.
4. Carefully pry bushing, fuel filter, and lower fuel line (150,000 BTU/Hr model only) out of fuel tank.
5. Wash fuel filter with clean fuel and replace in tank.
6. Attach upper fuel line to fuel filter neck.
7. Replace side cover.

(150,000 BTU/Hr
Model Shown)

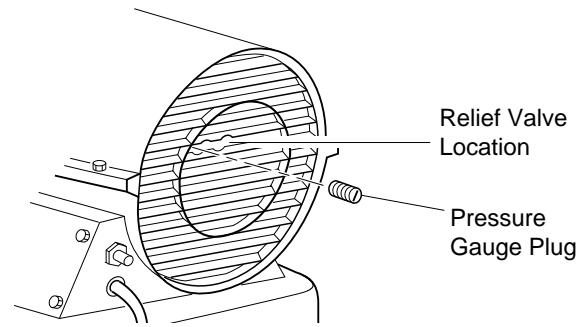

Figure 8 - Pressure Gauge Plug Removal

(150,000 BTU/Hr
Model Shown)

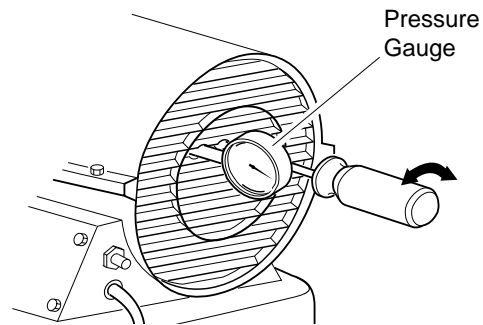
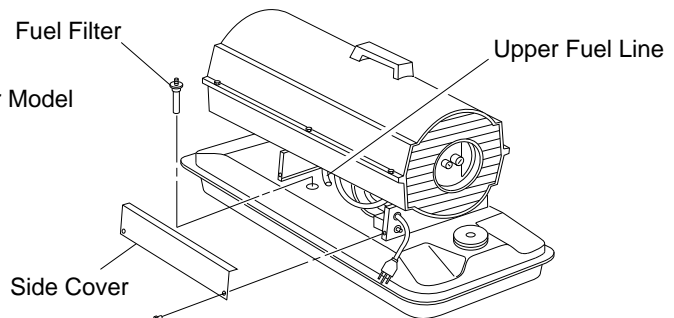

Figure 9 - Adjusting Pump Pressure

70,000 BTU/Hr Model



150,000 BTU/Hr Model

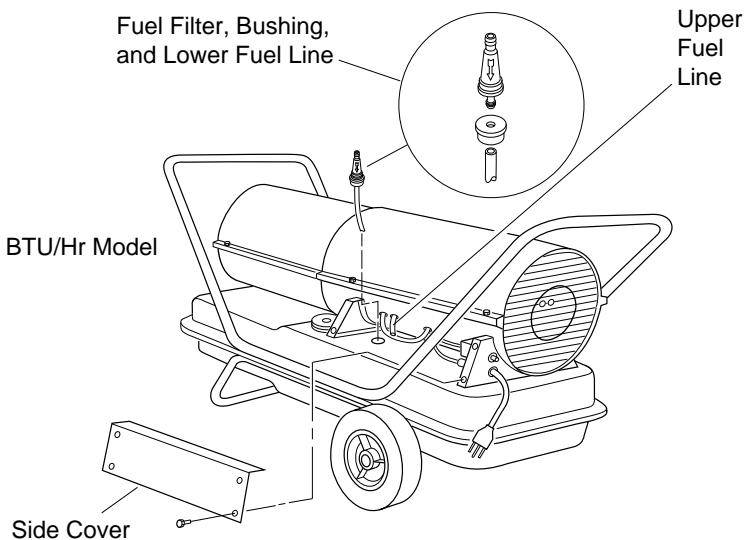

Figure 10 - Fuel Filter Removal

Spark Plug

1. Remove upper shell (see page 10).
2. Remove fan (see page 10).
3. Remove spark plug wire from spark plug.
4. Remove spark plug from burner head using 13/16" open-end wrench.
5. Clean and regap spark plug electrodes as follows:
70,000 BTU/Hr Model – .055" gap
150,000 BTU/Hr Model – .075" gap
6. Install spark plug in burner head.
7. Attach spark plug wire to spark plug.
8. Replace fan (see page 10).
9. Replace fan guard and upper shell.

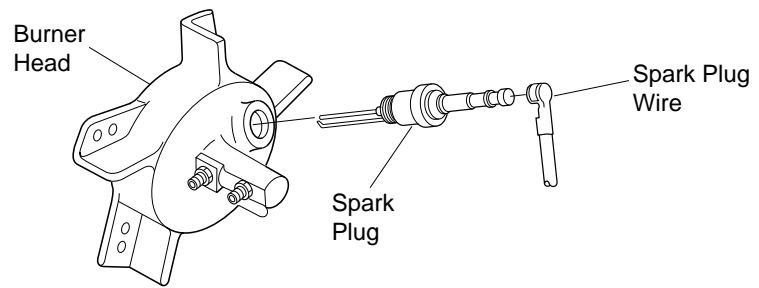

Figure 11 - Spark Plug Removal

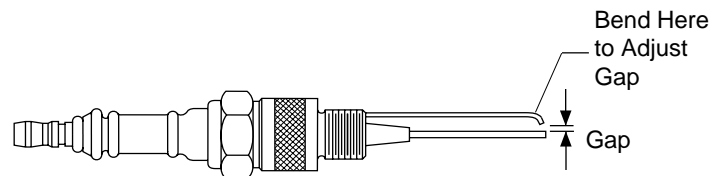

Figure 12 - Spark Plug Gap

Nozzle

1. Remove upper shell (see page 10).
2. Remove fan (see page 10).
3. Remove fuel and air line hoses from burner head.
4. Remove spark plug wire from spark plug.
5. Remove spark plug from burner head using 13/16" open-end wrench.
6. Remove three screws using 5/16" nut-driver and remove burner head from combustion chamber.
7. Place burner head into vise and lightly tighten.
8. Carefully remove nozzle from burner head using 5/8" socket wrench (see Figure 14).
9. Blow compressed air through face of nozzle. This will free any dirt in nozzle area.
10. Inspect nozzle seal for damage.
11. Replace nozzle into burner head and tighten firmly (80-110 inch-pounds).
12. Attach burner head to combustion chamber.
13. Install spark plug in burner head.
14. Attach spark plug wire to spark plug.
15. Attach fuel and airline hoses to burner head.
16. Replace fan (see page 10).
17. Replace fan guard and upper shell.

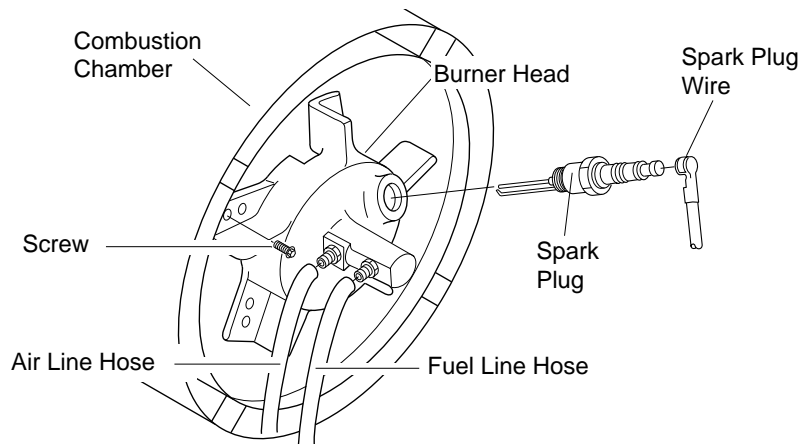

Figure 13 - Removing Burner Head

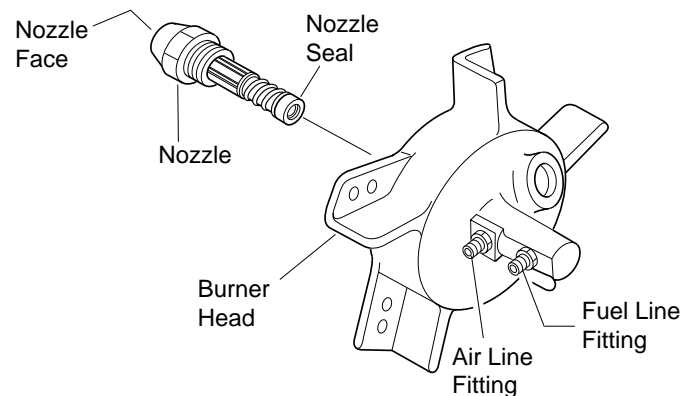

Figure 14 - Removing Nozzle

Pump Rotor

(Procedure if rotor is binding)

1. Remove upper shell (see page 10).
2. Remove filter end cover screws using 5/16" nut-driver.
3. Remove filter end cover and air filters.
4. Remove pump plate screws using 5/16" nut-driver.
5. Remove pump plate.
6. Remove rotor, insert, and blades.
7. Check for debris in pump. If debris is found, blow out with compressed air.
8. Install insert and rotor.
9. Check gap on rotor. Adjust to .003"/.004" if needed (see Figure 16).

Note: Rotate rotor one full turn to insure the gap is .003"/.004" at tightest position. Adjust if needed.

10. Install blades, pump plate, air filters, and filter end cover.
11. Replace fan guard and upper shell.
12. Adjust pump pressure (see page 11).

Note: If rotor is still binding, proceed as follows.

13. Perform steps 1 through 6 above.
14. Place fine grade sandpaper (600 grit) on flat surface. Sand rotor lightly in "figure 8" motion four times (see Figure 17).
15. Reinstall insert and rotor.
16. Perform steps 10 through 12 above.

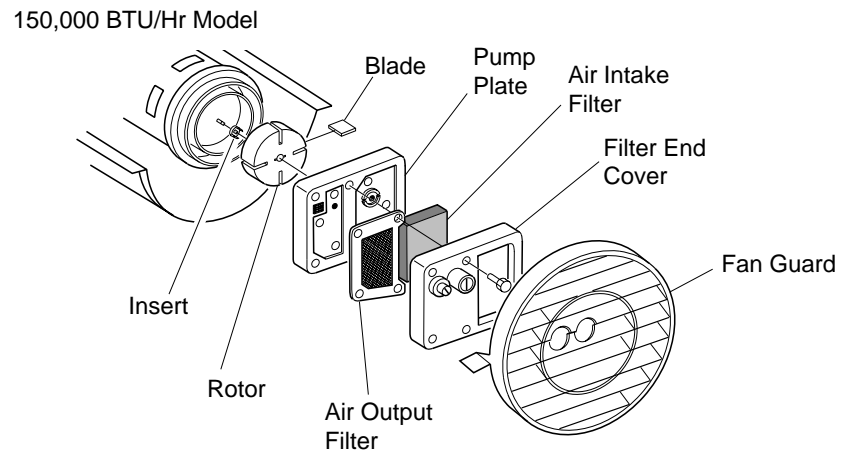
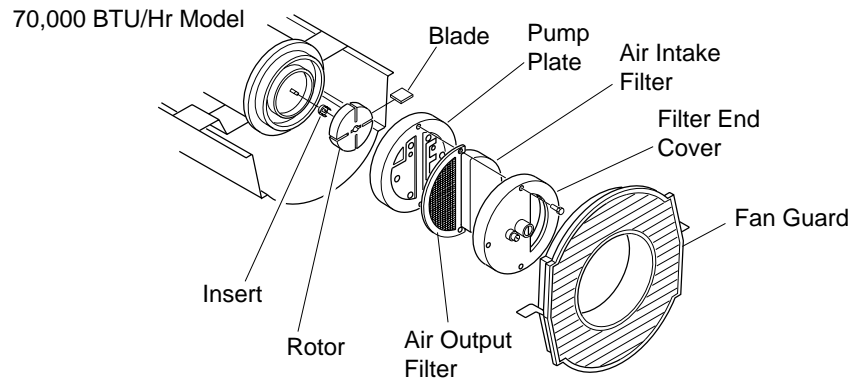

Figure 15 - Rotor Location

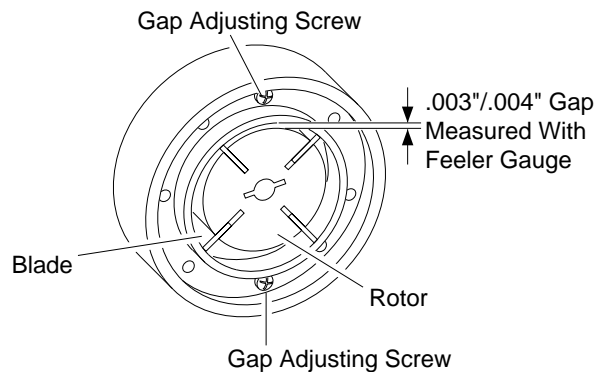

Figure 16 - Gap Adjusting Screw Locations

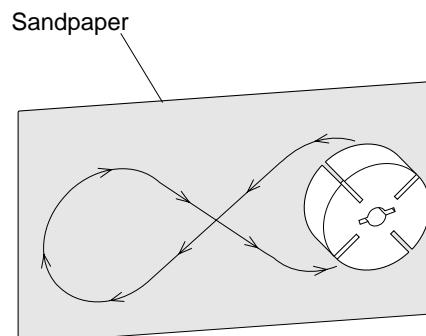

Figure 17 - Sanding Rotor

SPECIFICATIONS

Output Rating (BTU/Hr.)	70,000	150,000
Fuel	Use Only Kerosene or No. 1 Fuel Oil	
Fuel Tank Capacity (U.S. Gal.)	5.0	13.5
Fuel Consumption (Gal. Per Hr.)	0.52	1.10
Electric Requirements	120 V/60 Hz	120 V/60 Hz
Amperage (Normal Run)	2.5	4.5
Hot Air Output (CFM)	250	500

WIRING DIAGRAM

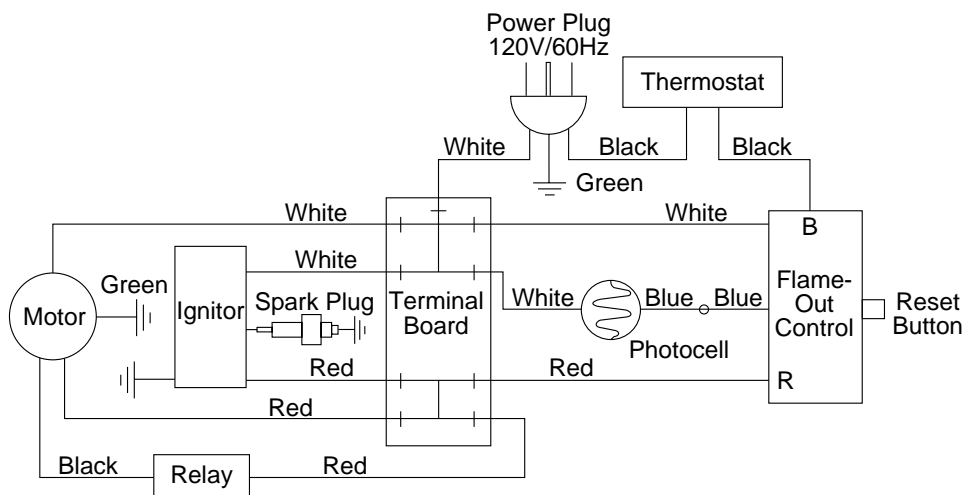

Figure 18 - Wiring Diagram

MAINTENANCE KITS

Kit	70,000 BTU/Hr Model	150,000 BTU/Hr Model
Flame Out Control	HA3003	HA3003
Spark Plug	HA3012	HA3012
Filter Kit	HA3014	HA3017
Nozzle Kit	HA3008	HA3010
Rotor/Air Pump Kit	HA3004	HA3004
Photocell	HA3019	HA3019
Pump Adjustment Handle	HA3020	HA2204

ACCESSORIES

Purchase accessories and parts from your nearest dealer or service center. If they can not supply these accessories or parts, either contact your nearest Parts Central or DESA International for information. Parts Centrals are listed in the Authorized Service Center booklet supplied with heater.

DESA International
P.O. Box 90004
Bowling Green, KY
42102-9004
1-800-972-7879
Parts Department

AIR GAUGE KIT - HA1180
 For all models. Special tool to check pump pressure.

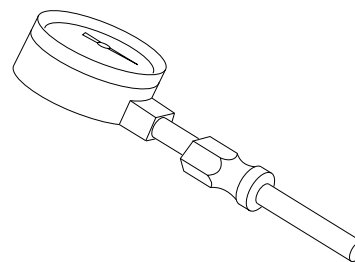

STANDARD WHEELS AND HANDLE KIT - HA1206
 Makes heater even more portable and convenient. Easy to assemble. For 70,000 BTU/Hr model only.

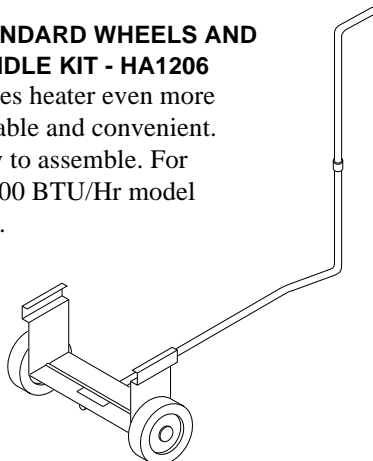

HEAVY DUTY WHEELS AND HANDLE KIT - HA1202

For heavy duty applications. Makes your heater even more portable and convenient. For 70,000 BTU/Hr model only.

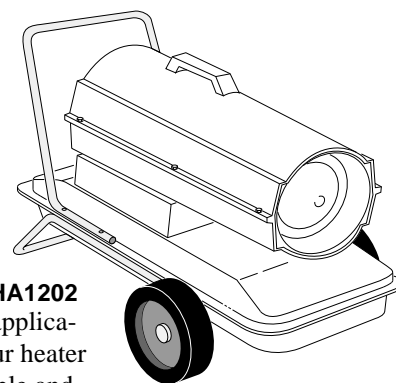

FLAME OUT CONTROL/PHOTOCELL TESTER - HA1170

For all models. Special tool used to test the flame out control and photocell.

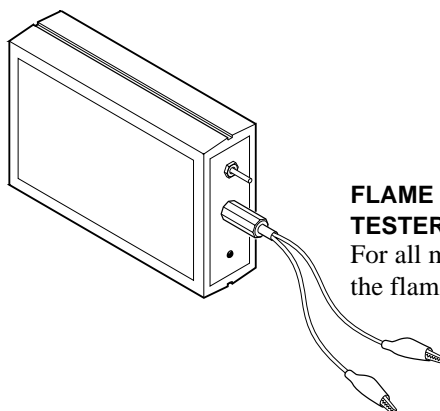

WARRANTY AND REPAIR SERVICE

LIMITED WARRANTY

DESA International warrants this product and any parts thereof, to be free from defects in materials and workmanship for six (6) months from the date of first purchase when operated and maintained in accordance with instructions. This warranty is extended only to the original retail purchaser, when proof of purchase is provided.

This warranty covers only the cost of parts and labor required to restore the product to proper operating condition. Transportation and incidental costs associated with warranty repairs are not reimbursable under this warranty.

Warranty service is available only through authorized dealers and service centers.

This warranty does not cover defects resulting from misuse, abuse, negligence, accidents, lack of proper maintenance, normal wear, alteration, modification, tampering, contaminated fuels, repair using improper parts, or repair by anyone other than an authorized dealer or service center. Routine maintenance is the responsibility of the owner.

THIS EXPRESS WARRANTY IS GIVEN IN LIEU OF ANY OTHER WARRANTY EITHER EXPRESSED OR IMPLIED, INCLUDING WARRANTIES OF MERCHANTABILITY AND FITNESS FOR A PARTICULAR PURPOSE.

DESA International assumes no responsibility for indirect, incidental or consequential damages. Some states do not allow the exclusion or limitation of incidental or consequential damages or limitations or exclusions may not apply to you. This Limited Warranty gives you specific legal rights and you may also have other rights which vary from state to state.

WARRANTY SERVICE

Should your heater require service, return it to your nearest authorized service center. Proof of purchase must be presented with the heater. The heater will be inspected. A defect may be caused by faulty materials or workmanship. If so, DESA International will repair or replace the heater without charge.

REPAIR SERVICE

Return the heater to your nearest authorized service center. Repairs not covered by the warranty will be billed at standard prices.

Illustrated parts lists can be obtained free of charge. Send a self addressed stamped envelope to the address listed below. List the heater model number and the date located in the lower right corner of this page. A service manual may be purchased from the address listed below. Send a check for \$5.00 payable to DESA International.

When writing for information regarding your heater, be sure to include the model number and serial number as shown on the model plate.

Each Service Center is independently owned and operated. We reserve the right to amend these specifications at any time without notice.

KEEP THIS WARRANTY

Model No. _____
Serial No. _____
Date of Purchase _____

(To be filled in by purchaser)

DESA
INTERNATIONAL
Corporate Headquarters
2701 Industrial Drive
P.O. Box 90004
Bowling Green, KY 42102-9004

For information, write: DESA International, P.O. Box 90004
Bowling Green, Kentucky 42102-9004 ATTN: Customer Service Department
When writing, always include model number and serial number.

100622-01
Rev. D
2/95