

PORTABLE FORCED AIR HEATER

Illustrated Parts List

Issued: Sept., 1990
MASTER – B150F
REDDY – R150B
DESA – C150F
KNIPCO – F150H
REMINGTON –
REM150A

IMPORTANT: Do not use key numbers when ordering service parts. Always order components by part number and description. Include model and serial numbers.

KEY NO.	PART NUMBER	DESCRIPTION	QTY.	KEY NO.	PART NUMBER	DESCRIPTION	QTY.
1	098511-138	Upper Shell (B150F)	1	23	M50814-03	Airline	1
	098511-135	Upper Shell (R150B)	1	24	098511-140	Lower Shell (B150F)	1
	098511-147	Upper Shell (C150F)	1		098511-137	Lower Shell (R150B)	1
	098511-135	Upper Shell (F150H)	1		098511-142	Lower Shell (C150F)	1
	098511-66	Upper Shell (REM150A)	1		098511-137	Lower Shell (F150H)	1
2	M11084-27	Screw, #10-16 x 1/2"	8		098511-82	Lower Shell (REM150A)	1
3	098512-29	Combustion Chamber	1	25	M30865-02	Bushing	3
4	099229-01	Photocell Bracket	1	26	M50104-02	Bushing	1
5	M10908-2	Screw, #6-32 x 3/8"	2	27	M11084-27	Screw, #10-16 x 1/2"	6
6	HA3019	Photocell Assembly	1	28	M11271-8	Clip Nut	8
7	***	Burner Head Assembly	1	29	M15823-37	Screw, #8-18 x 1/4"	1
7-1	HA3010	Nozzle with Sleeve	1	30	098513-55	Fuel Tank	1
7-2	M10659-1	Nozzle Washer	2	31	097702-01	Fuel Cap (Includes Gasket)	1
7-3	M10809-1	Nozzle Spring	1	32	HA3003	Safety Control	1
7-4	M8882	Nozzle Sleeve	1	33	M11143-1	Strain Relief Bushing	1
7-5	M50924-03	Burner Head Body	1	34	098219-19	Power Cord	1
7-6	M50820-02	Barb Fitting	2	35	M51077-01AA	Side Cover	1
7-7	HA3012	Spark Plug	1	36	M11084-27	Screw, #10-16 x 1/2"	4
8	M11084-27	Screw, #10-16 x 1/2"	3	37	099125-03	Terminal Board	1
9	097293-01	Fan	1	38	099157-01	Rivet	1
10	***	Motor and Pump Assembly	1	39	079010-18	Wire Assembly (Red, 14 1/2")	1
10-1	097300-02	Motor (Split Phase)	1	40	M16841-57	Wire Assembly (Red, 6")	1
10-2	079975-02	Pump Body	1	41	M27417	Drain Plug (Includes "O" Ring)	1
10-3	FHPF3-2C	Screw, #10-32 x 1/2"	2	PARTS AVAILABLE - NOT SHOWN			
10-4	M22009**	Rotor Insert	1		097896-01	Wheels	2
10-5	M22456-1**	Pump Rotor	1		M16801-2	Axle	1
10-6	M50545	Pump End Cover	1		M12831-3	Wheel Support Frame	1
10-7	M12179**	Intake Filter	1		HA2204	Front Handle	1
10-8	M16545	Filter End Cover	1		M12345-33	Screw, #10-24 x 1 3/4"	8
10-9	M8940**	Steel Ball, 1/4" diameter	1		M28526	Nut cap	2
10-10	M10993-1**	Relief Spring	1		NTC-3C	Hex Lock Nut, #10-24	8
10-11	M27694**	Adjusting Screw	1		097643-01	Tradename Decal (B150F)	
10-12	M22997**	Plug	1		097204-05	Tradename Decal (R150B)	
10-13	M12461-31	Screw, #10-32 x 1"	10		079872-01	Tradename Decal (C150F)	
10-14	M12244-1**	Output Filter	1		M29936	Tradename Decal (F150H)	
10-15	M11637**	Lint Filter	1		097773-02	Tradename Decal (REM150A)	
10-16	M50820-02	Barb Fitting	1		098493-01	General Information Decal	
10-17	M8643**	Blade	4		099176-01	Owner's Manual	
11	M50631	Rubber Bumper	2	OPTIONAL ACCESSORIES			
12	101206-01	Motor Mounting Bracket	1		HA1210	Hang-up Thermostat	
13	097061-01	Solid State Relay	1		HA1180	Air Gauge Kit	
14	M15823-39	Screw, #8-18 x 1/2"	2		HA2210	Fuel Tank Filter Screen	
15	NTC-4C	Hex Lock Nut, 1/4-20	2		HA3004	Rotor Kit (M22456-1, M22009, M8643)	
16	M51114-01	Fan Guard	1		HA3017	Filter Kit (M11637, M12179, M12244-1, M51150-01)	
17	102482-01	Ignitor Kit	1		HA3020	Pump Kit (M27694, M10993-1, M22997, M8940)	
18	M11084-29	Screw, #10-16 x 3/4"	2				
19	M51345-02	Fuel Line	1				
20	M51150-01**	Fuel Filter	1				
21	M51151-02	Fuel Line Tube	1				
22	M10990-3	Rubber Bushing	1				

** See OPTIONAL ACCESSORIES

*** Not available as an assembly.

DESA International

2701 Industrial Drive, P.O. Box 90004
 Bowling Green, KY 42102-9004
 Technical Service Department 1-800-323-5190
 Parts Department 1-800-972-7879

099356-01
 REV. B
 05/97

HEATER EXPLODED VIEW

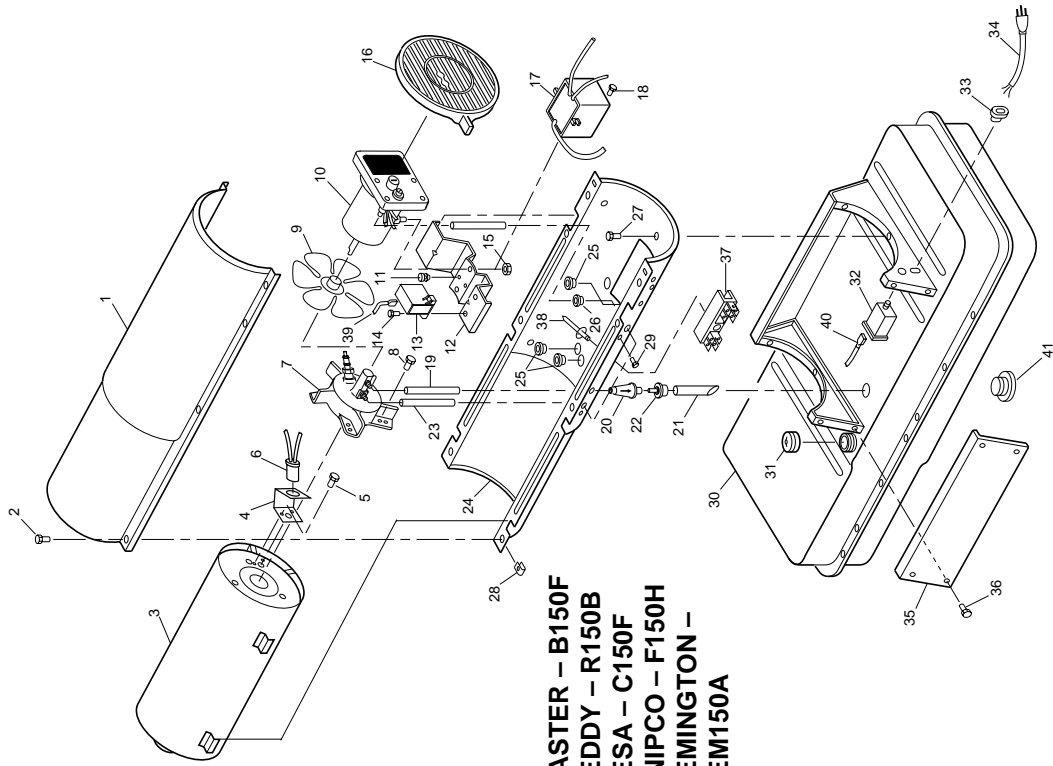

**MASTER – B150F
 REDDY – R150B
 DESA – C150F
 KNIPCO – F150H
 REMINGTON –
 REM150A**

MOTOR PACKAGE ASSEMBLY

10

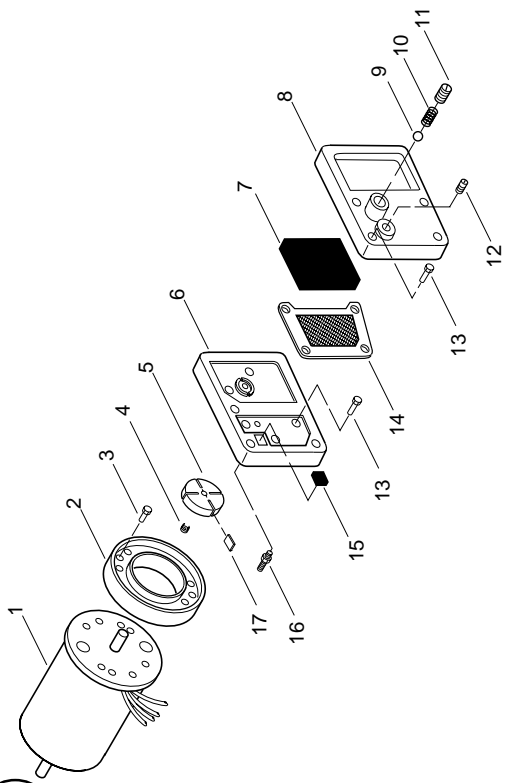

BURNER HEAD ASSEMBLY

7

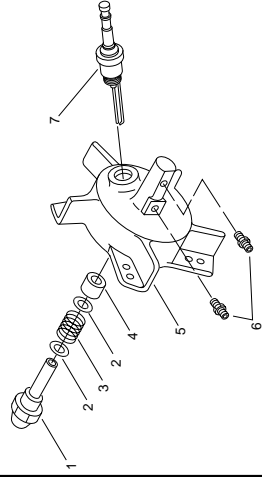

WIRING DIAGRAM

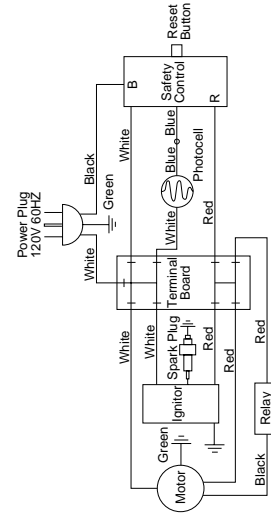

SPECIFICATIONS

Output Rating (BTU Per Hour)
 Fuel
 Fuel Tank Capacity (U. S. Gallons)
 Fuel Consumption (Approximate U.S. Gallons Per Hour)
 Electric Requirements
 Amperage (During Normal Run)
 Starting Amps

150,000
 Kerosene or #1 fuel oil
 13.5
 1.10
 120V/60Hz
 4.5
 10

Motor RPM
 Hot Air Output (Approximate CFM)
 Air Pump Pressure (PSI)
 Shipping Weight (Approximate Pounds)
 Heater Weight Without Fuel (Approximate Pounds)

3450
 500
 5.0
 65
 54
 No Duct Recommended