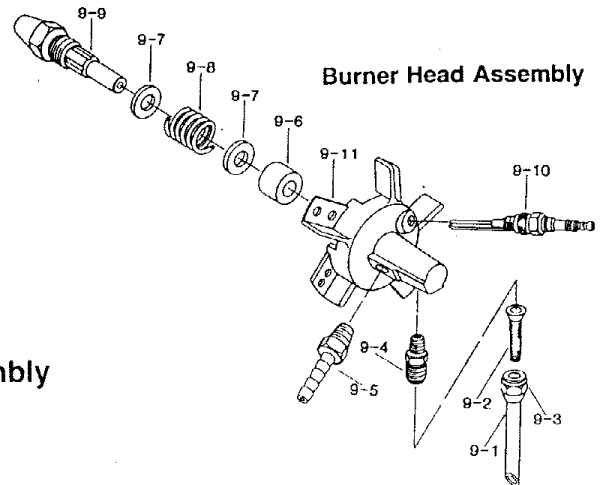
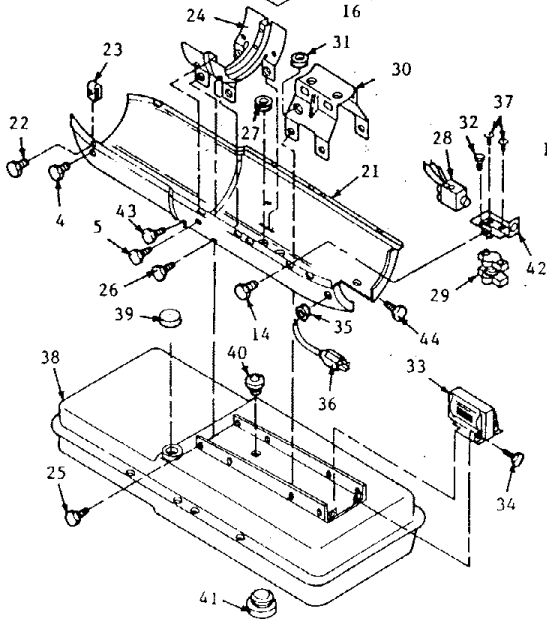
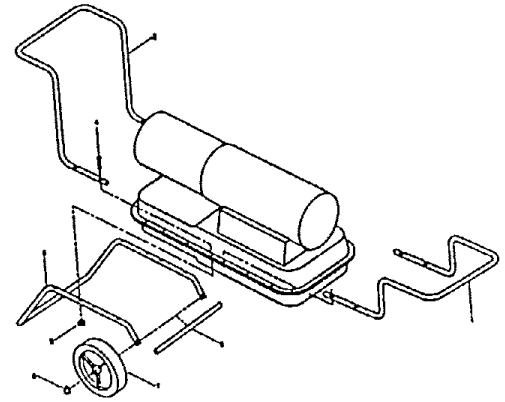
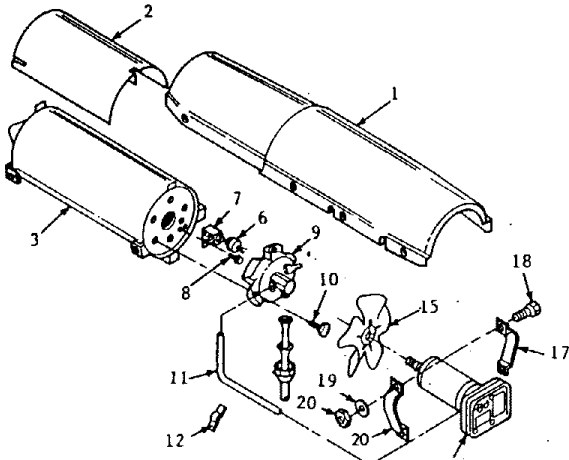

Figure 3 - Replacement Parts Illustration for Heater Model F150F

**KNIPCO Models F110E & F150F  
P/N Listing - Wheel/Handle Assembly**

REF NO.		F110E	QTY	F150F	QTY
1	Rear Handle	M13830-3	1	M14243-3	1
2	Front Handle	M51333-01	1	M14244-3	1
3	Support Frame	M12342-3	1	M12831-3	1
4	Screw, #10-24 x 1 3/4	M12345-33	8	M12345-33	8
5	Torque lock nut, #10-24	NTC-3C	8	NTC-3C	8
6	Axle	M51015-01	1	M16801-2	1
7	Wheel	M19294	2	M19294	2
8	Cap nut	M28526	2	M28526	2



**Motor and Pump Assembly**

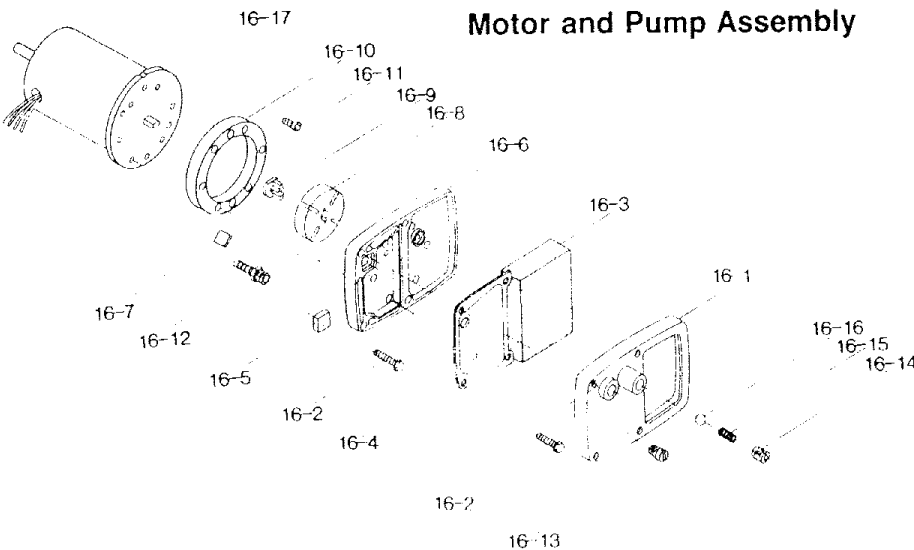

### Replacement Parts List for Heater Model F150F

KEY NO.	PART NUMBER	PART DESCRIPTION	QTY	KEY NO.	PART NUMBER	PART DESCRIPTION	QTY
1	M17014AD	Shell, Upper	1	16-15	M10993-1	Spring, Relief	1
2	M16679	Deflector, Heat	1	16-16	M8940	Ball, 1/4 dia.	1
3	M16887-6	Chamber, Combustion, Assembly	1	16-17	M51159-01	Motor, w/relay	1
4	M11084-27	Screw, Hex Hd., 10-16 x 1/2	2	17	M16661	Clamp, Motor	4
5	M11084-29	Screw, 10-16 x 3/4	2	18	M51043-01	Screw, Motor Clamp, 1/4-20 x 1 1/2	2
6	M16656-4	Photocell Assembly	1	19	WLM-4C	Lockwasher 1/4 in.	2
7	M16660	Bracket, Photocell	1	20	NPC-4C	Nut, Hex 1/4-20	2
8	M10908-2	Screw, Hex Hd., 6-32 x 3/8	2	21	M16810AD	Shell, Lower	1
9		Burner Head Assembly	1	22	M11084-27	Screw, Hex Hd., 10-16 x 1/2	6
9-1	M16790-12	Fuel Line	1	23	M11271-6	Nut, Clip	6
9-2	M19630	Filter, Screen Fuel	1	24	M12828	Bracket, Shell Support	1
9-3	M50660-05	Nut, Flare	1	25	M11084-27	Screw, Hex Hd., 10-16 x 1/2	8
9-4	079685-01	Connector, Male	1	26	M11084-29	Screw, #10-16 x 3/4	2
9-5	M50817-01	Fitting, Barb	1	27	1000576	Grommet Leads Thru Lower Shell	2
9-6	M8882	Seal, Nozzle	1	28	M50671-01	Control, Safety	1
9-7	M10659-1	Washer, Nozzle	2	29	M12462-17	Relay, Motor Start	1
9-8	M10809-1	Spring, Nozzle	1	30	M16645	Bracket, Motor Support	1
9-9	M18022	Nozzle, 1.1 GPH	1	31	1000577	Grommet	1
9-10	M10962-2	Spark Plug	1	32	M11084-27	Screw, #10-16 x 1/2 (Grounding)	1
9-11	M50924-01	Body, Burner Head	1	33	M16697-02	Transformer	1
10	M11084-27	Screw, Hex Hd., 10-16 x 1/2	3	34	11084-27	Screw #10-16 x 1/2	2
11	M50814-03	Airline, Tubing	1	35	M11143-1	Bushing, Strain Relief	1
12	M50873-01	Clip, Airline	2	36	M10813-86	Cord, Power	1
13	M16841-16	Wire Assembly (red)	2	37	M12461-13	Screw, Rd. Hd., 8-32 x 1/4	2
14	M11084-27	Screw, #10-16 x 1/2	1	38	M51090-15	Tank, Fuel	1
15	M17058	Fan	1	39	M51027-06	Cap, Fuel	1
16		Motor & Pump Assembly	1	40	M10990-3	Bushing, Rubber, Fuel Line Into Fuel Tank	1
16-1	M16545	Cover, End Filter	1	41	M27417	Plug, Drain, Includes "O" Ring	1
16-2	M12461-31	Screw, #10-32 x 1	10	42	M25296-1	Bracket, Relay	1
16-3	M12179	Filter, Intake	1	43	M11084-27	Screw, #10-16 x 1/2	2
16-4	M12244-1	Filter, Output	1	44	M11084-27	Screw, #10-16 x 1/2	2
16-5	M11637	Filter, Lint	1				
16-6	M50545	Cover, End Pump	1				
16-7	M8643	Blade	4				
16-8	M22456-1	Rotor Pump	1				
16-9	M22009	Insert, Rotor	1				
16-10	M8645	Body, Pump	1				
16-11	FHPF3-4C	Screw, #10-32 x 1/2	2				
16-12	M50817-01	Fitting, Barb	1				
16-13	M22997	Plug	1				
16-14	M27694	Screw, Adjusting	1				

**PARTS AVAILABLE - NOT SHOWN**

M51138-04	Decal, Wiring Diagram
079698-01	Decal, General Information
M29936	Decal, Tradename
M13942-7	Connector, Wire (Blue Wires) 1
M13942-5	Connector, Wire (Red Wires) 1
M13942-6	Connector, Wire (White Wires) 1

MODEL F150F

