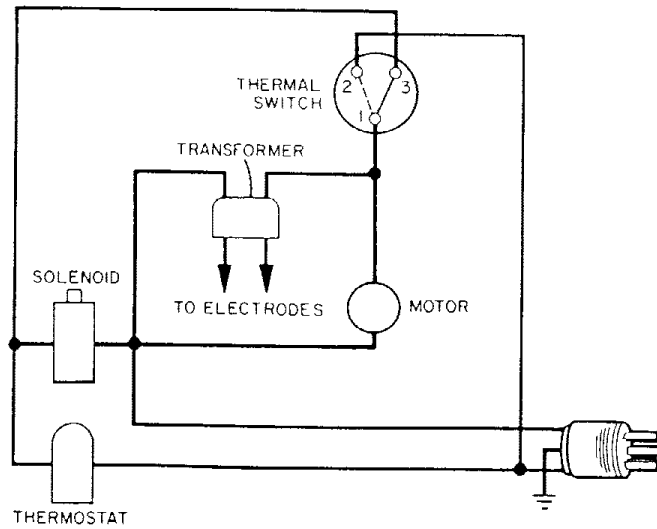

Figure 4. Heater Exploded View

Figure 3. Wiring Diagram



SECTION III PARTS LIST

This section contains a list of all service parts used in the equipment covered by this manual. Standard hardware items are indicated by the symbol (*).

of the equipment. Include the model, specification, and serial numbers when ordering parts. Order parts by part name and part number only. Do not use index numbers from the illustration when ordering parts.

Check the model decal for correct model number

FIG. & INDEX NO.	PART NUMBER	PART NAME	3012G04	3102G02
4- 1	M14244A	Handle, Front	1	1
	*M12345-34	Screw, Machine, Oval hd. 10-24 x 2 in.	4	4
	NTC-3C	Nut, Torque lock 10-24	4	4
2	M19810B	Cone, Nose	1	1
	*M11084-27	Screw, Self-Tapping, hex hd. No. 10-32 x 1/2 (Nose Cone to Outer Shell)	4	6
3	M19805-1B	Shell Assy, Outer	1	1
	*M11084-27	Screw, Self-tapping, hex hd. No. 10-32 x 1/2 (Outer Shell to tank)	6	6
	*M10908-27	Screw, Self-tapping, hex hd. No. 10-32 x 1/2 (Outer Shell to Combustion Chamber)	4	4
4	M3364B	Cowl	4	4
	*M11084-28	Screw, Self-tapping, hex hd. No. 10-12 x 5/8, Type A (Cowl to Outer Shell)	1	1
	M11271-6	Nut, Tinnerman (Cowl to Outer Shell)	3	3
5	M17670	Thermostat Assy	1	-
	M17696	Thermostat Assy.	-	1
	*ST1-2BC	Screw, Rd. hd. No. 6-18 x 1/4 in. (Thermostat)	2	2
6	M15814B	Bracket, Thermostat	1	1
	*M11084-27	Screw, Self-tapping, hex hd. No. 10-12 x 1/2	1	1
7	M9758G6	Combustion Chamber Assy	1	1
8	M9107G1	Burner Head Assy	1	1
9	*RC1-2	. Screw, Rd. hd. No. 6-32 x 1/4	2	2
10	M9108	. Nozzle	1	1
11	M4274	. Nozzle Spring	1	1
12	M3978	. Air Deflector	1	1
13	*HF3-3	. Screw, Hex hd., No. 10-32 x 3/8	2	2
14	M16712	. Electrode Bushing	2	2
15	M10947	. Body, Burner	1	1
16	M3981	. Electrode	2	2
17	M2294	. Elbow Compression, 90°	1	1
18	*M12461-16	Screw Hex hd. No. 8-32 x 5/8	2	2
19	M9928	Fan	1	1
20	M18025	Key, Fan Locating	1	1
21	M3247	Fan Guard Assembly	1	1
22	REF	Motor and Pump Assy (See figure 5)	1	-
	REF	Motor and Pump Assy (See figure 6)	-	1
	*HC4-6C	Screw, Hex hd., 1/4-20 x 3/4	4	4
	*NTC-4	Nut, Torque Lock 1/4-20	4	4
	1001349	Connector, Straight (Solenoid Leads)	1	1
23	M19836	Fuel Line	1	-
	M22875	Fuel Line	-	1
23A	1000577	Grommet (Fuel line to shell)	1	1
24	M19809A	Handle, Rear	1	1
	*M12345-34	Screw, Oval hd. 10-24 x 2	4	4
	*M12345-31	Screw, Oval hd. 10-24 x 1-1/4	2	2
	*Standard Hardware.	Procure locally.		

KNIPCO PORTABLE HEATER MODEL F-155A Spec. No. 3012G04 & 3102G02
 Form No. 2661-1 (2/71)

FIG. & INDEX NO.	PART NUMBER	PART NAME	3012G04	3102G02
4-	*NTC-3C	Nut, Torque Lock 10-24	6	6
	*WP-3C	Washer, Flat	2	2
25		Deleted		
26		Deleted		
27		Deleted		
28	M19916-1	Wiring Harness Assy	1	1
29	M5895	Switch, Thermal	1	1
	M8152	Spacer, (Thermal switch to burner head)	2	2
	*M11084-40	Screw, Self-tapping, Hex hd. No. 8-15 x 5/8 in. Type A (Thermal switch to burner head)	2	2
30	1000576	Grommet (Electrode Leads through shell)	2	2
31	M10816G36	Lead, Electrode	2	2
32	M4785	Fin, Deflector	1	1
	*M11084-38	Screw, Self-tapping Hex hd. No. 8-15 x 3/8, Type A	2	2
33	M6821	Grommet (Deflector fin)	1	1
34	M8633-2B	Door, Access	1	1
	*M11084-40	Screw, Self-tapping, Hex hd. No. 8-15 x 5/8 in.	2	1
	M11271-5	Nut, Tinnerman	2	2
35	M5837	Cover, Box	1	1
36	M6016	Box, Utility	1	1
	*HF3-4C	Screw, Hex hd. 10-32 x 1/2	2	2
	*NTF-3C	Nut, Torque Lock 10-32	2	2
37	M3530	Grommet	5	4
38	M10813G12	Extension Cord Assy	1	1
	1001349	Connector, Straight	1	1
	M13942-4	Connector, Wire	4	4
39	M3334G10	Fuel Line Assembly	2	2
39A	M18919-2	Intake Tube Assy	2	2
40	M19807A	Bracket, Motor Support	1	1
41	M19808A	Bracket, Transformer Support	1	1
	*M12461-52	Screw, Hex hd. No. 10-24 x 5/8	5	5
	*WP-3C	Washer, Plain	5	5
	*NTC-3C	Nut, Torque Lock	5	5
42	M13990	Plug, Pipe 1/4 in.	1	1
43	M16801-2	Axle	1	1
44	*WP-8C	Washer, Flat	2	2
45	M16741-15	Ring, Retaining	2	2
46	M19295	Wheel	2	2
47		Deleted		
48	M12831A	Frame, Wheel Support	1	1
49	M19518-1	Transformer, Lead Alteration	1	1
	*NPC-4C	Nut, Hex 1/4-20 (Transformer to Bracket)	2	2
	*WLM-4C	Lockwasher (Transformer to Bracket)	2	2
50	M18051	Cap, Filler Neck	1	1
51	M18053	Screen, Filler Neck	1	1
52	M19801-1A	Fuel Tank Assy	1	1
	M17071	Decal, Trade name	1	1
	M19824	Decal, Nameplate	1	-
	M19825-4	Decal, Model	1	-
	M9134	Decal, Wiring	1	1
	M18196	Decal, Mfg. By	1	1
	M16420	Decal, Caution	1	-
	M20532-3	Decal, Pump Prime	1	1
	M3486-5	Tubing, Varnished	1	-
	M3486-4	Tubing, Varnished (Solenoid leads)	-	1
	M22743	Decal, Warning	-	1
	M22888-2	Decal, Model	-	1
	M22887	Decal, Nameplate	-	1
		Touch-up Paint - Aerosol Can		
	M13386-3	Green		
	M13386-8	Black		
	M13386-4	Yellow		

*Standard hardware, obtainable locally.

KNIPCO PORTABLE HEATER MODEL F-155A Spec. No. 3012G04 & 3102G02

FIG. & INDEX NO.	PART NUMBER	PART NAME	QTY.
5-		Motor and Pump Assy (See 22, figure 4)	N/A
1	57413	Elbow, Street 1/4 in.	1
2	M3973	Filter	1
	M4307	. Filter Can	1
	M3301-2	. Filter Gasket	1
	M3301	. Filter Element	1
3	M20480	Nipple, Pipe, 1/4 x 2-1/2 in.	1
4	57379	Elbow, Street, 1/8 pipe x 1/8 pipe	1
5	69246	Nipple, Hex, 1/8 pipe	1
6	M3974-5	Solenoid Assy	1
7	1000513	Connector, Male	1
8	M18364	Pump	1
9	*HC5-7C	Screw, Hex hd, 5/16-18 x 3/4 in.	4
10	*WLM-5C	Washer, Lock 5/16 in.	4
11	*WP-5C	Washer, Plain 5/16 (Bottom only)	2
12	M18365	Adaptor	1
13	*RF3-6	Screw, Round Hd., No. 10-32 x 3/4 in.	3
14	*WLM-3	Washer, Lock, No. 10	3
15	M18436	Spring	1
16	M18366	Coupling	1
17	M9809-2	Motor	1
18	M12650-8	Capacitor	1

N/A - Not available as an assembly. Order individual parts if required.
 * Standard Hardware, obtainable locally.

Form No. 2661-1
(2/71)

Figure 5. Motor and Pump Assembly, Spec. No. 3012G04

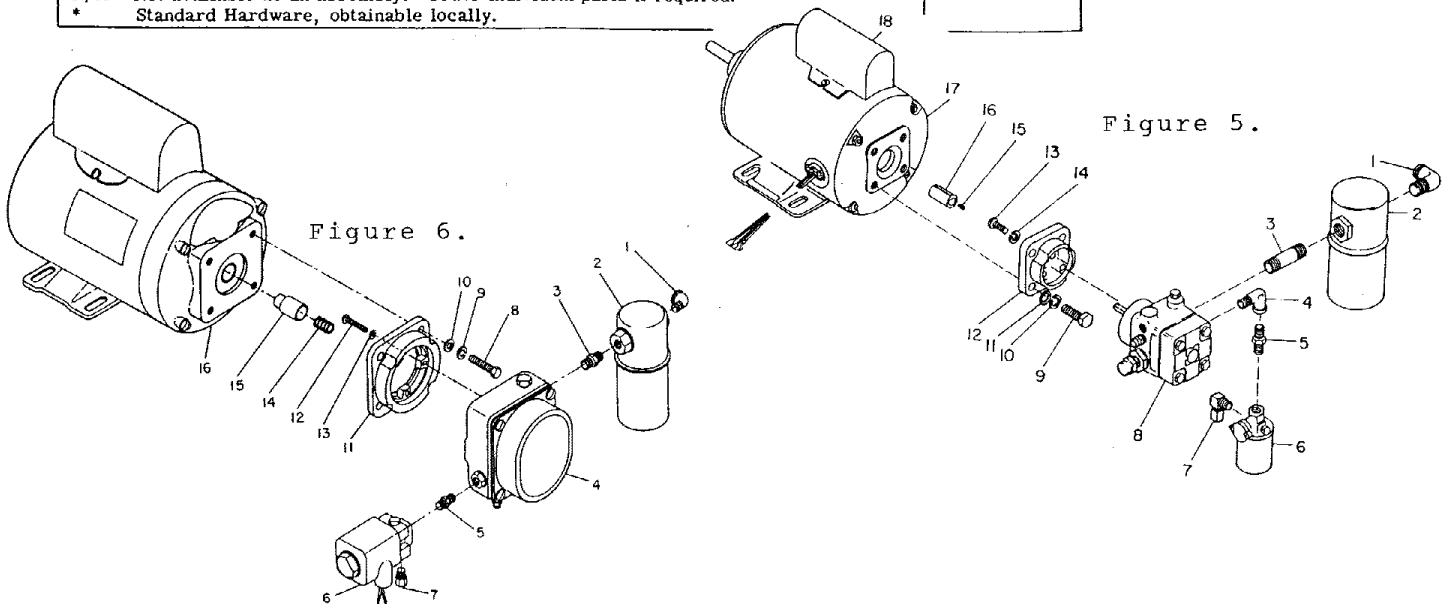

Figure 6. Motor and Pump Assembly Spec. No. 3102G02

FIG. & INDEX NO.	PART NUMBER	PART NAME	QTY.
6-		Motor and Pump Assy	N/A
1	57413	Elbow, Street 1/4 in.	2
2	M3973	Filter, Fuel	1
	M4307	. Filter Can	1
	M3301-2	. Filter Gasket	1
	M3301	. Filter Element	1
3	M3463	Nipple	1
4	M22872-1	Pump, Fuel	1
5	69246	Nipple, Pipe 1/8 in.	1
6	M3974-2	Valve, Solenoid	1
7	1000513	Connector, Male	1
8	*HC5-7C	Screw, Hex hd. 5/16-18 x 3/4 in.	4
9	*WLM-5C	Lockwasher 5/16 in.	4
10	*WP-5C	Washer, Plain 5/16 in.	4
11	M22348	Adaptor	1
12	*RF3-6	Screw, Rd. hd., No. 10-32 x 3/4 in.	3
13	*WLM-3	Lockwasher No. 10	3
14	M18436	Spring	1
15	M22873	Coupling	1
16	M19915	Motor, Lead Alteration	1

N/A Not available as a service part. Order individual parts.
 * Standard Hardware. Procure locally.