

Figure 13. Portable Heater, Exploded View

1	M15813A	Handle, Front and Rear	2
2	M12831B	Frame, Wheel support	1
3	M12345-31	Screw	2
4	M12345-34	Screw	8
5	WP-3C	Washer, Flat No. 10	2
6	NTC-3C	Nut, Torque lock No. 10-24	10
7	M16741-15	Ring, Retaining	2
8	WP-8C	Washer, Flat, 1/2 inch	2
9	M19294	Wheel	2
10	M16801-2	Axle	1

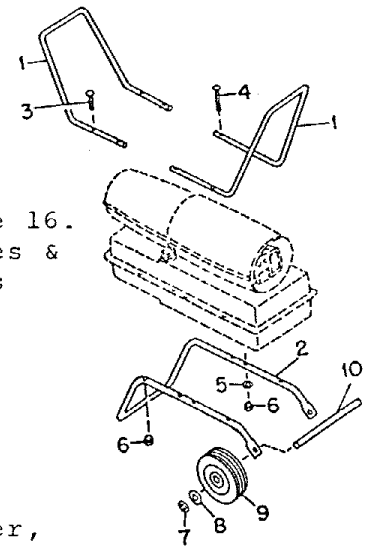
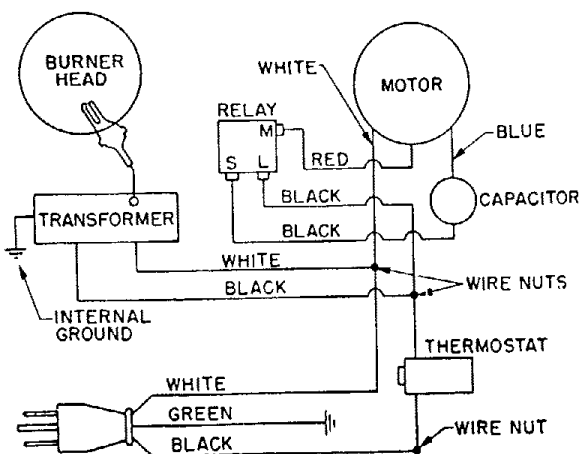

Figure 16. Handles & Wheels

MODEL 150



MODEL 150S

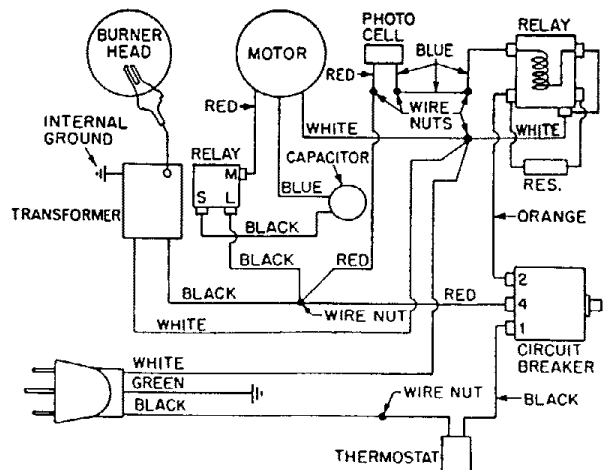

Figure 9. Wiring Diagram

AMOCO MODEL AM-150 and AM-150S
 Spec. No. 3059G8 and 3059G32
 Form No. 2645-2 (6/72)

Index No.	Part Number	Part Name or Description	Ref. Notes	Qty.
1	M17015-1J	Shell Assy, Upper	¢	1
2	M16679	Deflector, Heat		1
3	M16887-6	Combustion Chamber		1
-	M11084-27	Screw (Combustion Chamber attaching, front)	\$	2
-	M11084-29	Screw (Combustion Chamber attaching, rear)	\$	2
4	M15995	Plug Button (Rear head of combustion chamber)	&	1
4A	M16656-1	Cell and Bushing Assy	x	1
4B	M16600	Bracket, Photo Cell	x	1
	M10908-1	Screw (Photo cell bracket to combustion chamber)	x	2
5	Ref.	<u>Burner Head Assembly</u> (See Figure 14)	@	1
-	M11084-27	Screw (Burner Head to Combustion Chamber)	\$	3
6	M16804	Air Line	@	1
6A	M12461-27	Screw (Clamp to retainer strap)	x	1
6B	M24717	Clamp, Tube	x	1
6C	WLM-3	Lockwasher, No. 10	x	1
6D	NPF-3C	Nut, Plain, No. 10-32	x	1
7	M16871	Strap, Retainer		1
-	M11084-27	Screw (Retainer Strap to Lower Shell)	\$	2
8	M17058	Fan, 16° Pitch		1
-	SF4-2-1/2K	Setscrew, Soc. hd., cup pt, 1/4-28 (Fan to Motor Shaft)		2
9	Ref.	<u>Motor Package Assembly</u> (See Figure 15)	@	1
10	M16661	Clamp, Motor		4
11	Not Used			
12	HC4-10C	Screw (Motor Clamps)	\$	2
13	WLM-4	Lockwasher, 1/4 in. (Motor Clamps)	\$	2
14	NPC-4C	Nut, Hex, 1/4-20 (Motor Clamps)		2
15	M16810J	Shell, Lower	¢	1
16	M11084-27	Screw (Upper Shell to Lower Shell)	\$	8
17	M11271-6	Nut, Tinnerman (Upper Shell to Lower Shell)	\$	8
18	M12828A	Bracket, Shell Support		1
-	M11084-27	Screw (Support Bracket to Lower Shell and Fuel Tank)	\$	6
-	M11084-29	Screw (Lower Shell to Support Bracket)	\$	2
19	1000576	Grommet (Ignition Cable thru Lower Shell, Thermostat Leads thru Lower Shell)	&	3
19	1000576	Grommet (Cables and Leads thru Lower Shell)	x	4
20	M15809	Plug Button (for 1/2" dia. hole)	&	1
21	Not Used			
22	M12650-1	Capacitor		1
23	M12651-1	Clamp, Tinnerman (Capacitor Mounting)		1
-	M11084-27	Screw (Capacitor Clamp to Motor Support Bracket)	\$	1

Index No.	Part Number	Part Name or Description	Ref. Notes	Qty.
24	M16645	Bracket, Motor Support		1
-	M11084-27	Screw (Motor Support Bracket to Lower Shell and Fuel Tank)	\$	6
25	1000577	Grommet (Motor and Capacitor Leads thru Motor Support Bracket)		2
-	M15823-26	Screw (Service Cord grounding to Motor Support Bracket)	\$	1
26	M16697	Transformer, 5000-Volt	@	1
-	M11084-27	Screw (Transformer to Motor Support Bracket)	\$	2
27	M11954	Bushing, Strain Relief (Service Cord to Lower Shell)		1
27A	M5890	Grommet	x	1
28	M10813-33	Service (Extension) Cord		1
29	M13942-2	Connector (Wire Nut)	\$&	1
-	M13942-2	Connector (Wire Nut)	\$x	4
	M13942-4	Connector (Wire Nut) approx. 7/8 in. long	\$	2
-	M9900-77	Wire Assy, (to Capacitor)		1
30	M18371-3D	Fuel Tank	¢&	1
30	M18371-3E	Fuel Tank	x	1
31	M18051	Cap, Fuel Tank		1
31A	M18053	Screen, Filler Neck		1
32	M10990-3	Bushing, Rubber (Fuel Filter into Fuel Tank)		1
33	M21040	Plug, Pipe, 1/4 in., Hex hd. (Fuel Tank Drain)	&	1
	M24973	Plug, Drain	x	1
34	M25297-1	<u>Thermostat Assembly</u>	x	1
-	M11084-37	Screw (Thermostat to Bracket)		4
35	M25121B	Bracket, Thermostat	x	1
-	RC1-3C	Screw (Thermostat Bracket to Lower Shell)		1
-	WLI-1	Lockwasher (Thermostat Bracket to Lower Shell)		1
	M18598-1	Relay and Bracket Assy	&	1
36	M12462-6	Relay, Starting	&	1
	RC2-2C	Screw (Relay to Relay Bracket)		2
	WLI-2	Lockwasher		2
37	M11952	Bracket, Mounting	&	1
	M16852-4	Relay and Bracket Assy	x	NA
38	M12462-6	Relay, Starting	x	1
39	RC2-2C	Screw (Relay to Relay Bracket)	x	2
40	M14378G1	Relay Assembly	x	1
41	M12461-2	Screw (Relay to Relay Bracket)	x	1
42	M14360	Circuit Breaker	x	1
43	M16851-1	Bracket Assy, Control	x	1
	M11084-27	Screw (Relay Mounting Bracket to Lower Shell)	\$	1
	ST2-2AC	Screw (Grounding)		2
	M9900-62	Wire Assy	\$	1
	M16615-1	Wiring Harness Assy	x	1
	M10908-1	Screw (Photocell bracket)	x	2
	M9900-61	Wire Assy	x	1

@ Parts recommended for normal replacement by owner or user.

x AM150S Models Only
 & AM150 Models Only

AMOCO MODEL AM-150 and AM-150S
Form No. 2645-2 (6/72)

Spec. No. 3059G8 and 3059H32

Index No.	Part Number	Part Name or Description	Ref. Notes	Qty.
-	M16803-4	<u>Burner Head Assembly</u> (See Fig. 13, Index No. 5)		NA
1	M16790-12	. Filter Tube	@	1
2	M19630	. Filter, Fuel	@	(1)
3	M13849	. Nut, Flare		1
4	M16741-18	. Ring, Retaining		1
	M16787-3	. Nozzle Adapter Assy		1
5	M16791	. . Connector, Male		1
6	M5976	. . Connector, Male		1
7	M8882	. . Sleeve, Nozzle Seal		1
8	M10659-1	. . Washer, Nozzle Seal		2
9	M10809-1	. . Spring, Nozzle Seal		1
10	M18022	. . Nozzle, Aspirating, 1/0 gph		1
11	M16535	. . Adapter, Nozzle		1
12	M12461-51	. . Screw, Hex hd.		1
13	M16895-1	. Spark Plug Assy	@	1
14	M23090	. Body, Burner Head		1

NA Not available as a service part - order details.

@ Parts recommended for normal replacement by owner or user.

STANDARD SCREWS

Part Number	Description
FHPF3-7C	Screw, Fillister hd, No. 10-32 x 7/8 in.
HC4-10C	Screw, Hex hd, Machine, 1/4-20 x 1-1/4 in.
M11084-27	Screw, Self-tapping, hex hd, No. 10-12 x 1/2 in., Type "A"
M11084-29	Screw, Self-tapping, hex hd, No. 10-12 x 3/4 in., Type "A"
M12345-31	Screw, Oval hd. machine, No. 10-24 x 1-1/4 in.
M12345-34	Screw, Oval hd. machine, No. 10-24 x 2 in.
M12461-31	Screw, Hex hd., No. 10-32 x 1 in.
M12461-34	Screw, Hex hd., No. 10-32 x 1-1/2 in.
M15823-26	Screw, Self-tapping, hex hd., No. 10-12 x 3/8 in., Type "B"
M10908-1	Screw, Self-tapping hex hd., No. 6-32 x 1/4 in., Type "S"
M12461-51	Screw, Hex hd., No. 10-24 x 1/2 in.
RC2-2C	Screw, Rd. Hd., 8-32 x 1/4 in.
M12461-2	Screw, Hex hd., No. 6-32 x 3/8 in.
M12461-27	Screw, Hex hd., No. 10-32 x 1/2 in.

Motor Package Assembly, Con't

10	M8643-3	. Blade		4
11	M22456-3	. Rotor		1
12	M22009	. Insert, Rotor		1
13	M8645-3	. Pump Body		1
14	FHPF3-7C	. Screw (Pump Body to Motor)	\$	2
15	M5976	. Connector, Male		1
16	M22997	. Plug		1
17	M23105	. Screw, Pressure Adjustment		1
18	M10993-1	. Spring, Compression (Pressure Relief)		1
19	M8940	. Ball, 1/4 in. dia.		1
20	M17814	. Motor		1
-	M16675G2	Kit, Pump and Filter		1
-	M20711-1	Kit, Motor Replacement (Replaces Motor M12811)		1
-	M20725-1	Kit, Motor Package Replacement (Replaces M12864G1 and M16674G1)		1

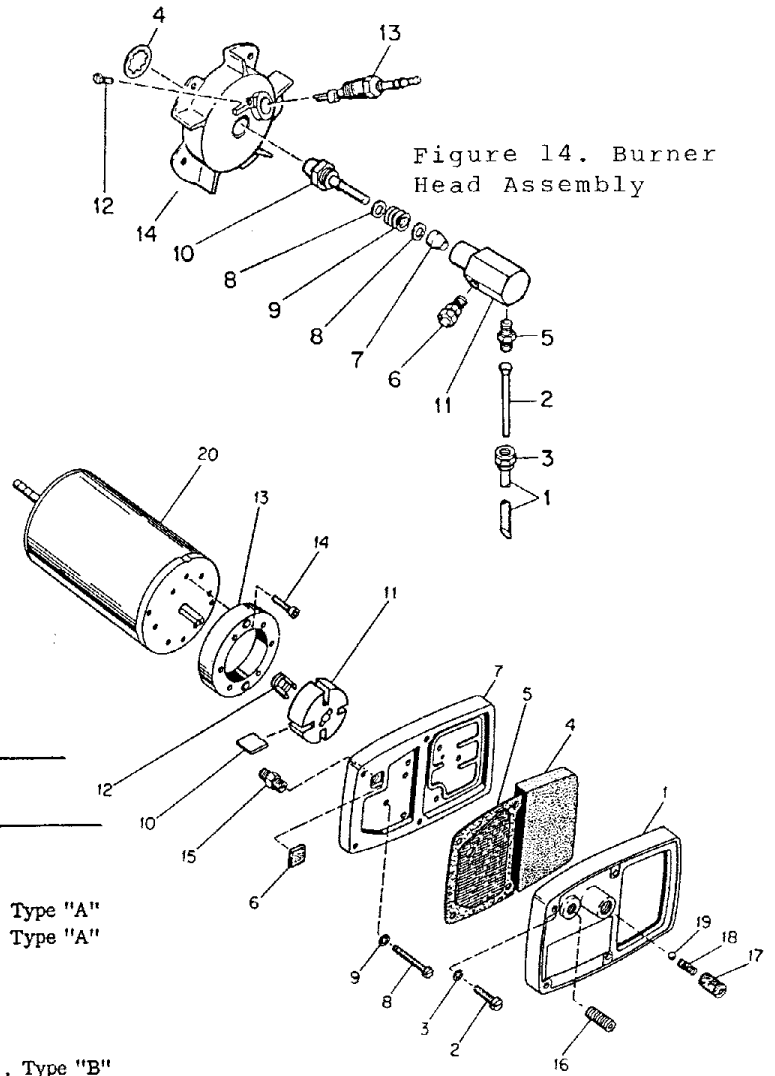

Figure 14. Burner Head Assembly

Figure 15. Motor Package Assembly

Index No.	Part Number	Part Name or Description	Ref. Notes	Qty.
-	M17875-1	<u>Motor Package Assembly</u> (See Figure 13, Index No. 9)	@	1
1	M16545	. End Cover, Filter		1
2	M12461-31	. Screw (Filter End Cover to Pump End Cover)	\$	4
3	WLI-3	. Lockwasher, Internal, No. 10	\$	4
4	M12179	. Intake Air Filter	@	1
5	M12244-1	. Output Filter Assy	@	1
6	M11637	. Filter, Lint	@	1
7	M12233	. End Cover, Pump (Port Plate)		1
8	M12461-34	. Screw (End Cover to Motor)	\$	6
9	WLI-3	. Lockwasher, Internal, No. 10	\$	6