

Index No.	Part Number	Part Name	Qty.
17-	M25023-1	Motor Package Assembly (See figure 15)	Ref.
1	M16545	. End Cover, Filter	1
2	*M12461-31	. Screw, Hex hd. No. 10-32 x 1 (AP)	4
3	*WLI-3	. Lockwasher, Internal No. 10 (AP)	4
4	M12179	. Intake Air Filter	1
5	M12244-1	. Output Filter Assy	1
6	M11637	. Filter, Lint	1
7	M12233	. Front Cover, Pump (Port Plate)	1
8	*M12461-32	. Screw, Hex hd, No. 10-32 x 1-1/8 (AP)	6
9	WLI-3	. Lockwasher, Internal No. 10 (AP)	6
10	M8643	. Blade, Pump	4
11	M22456-1	. Rotor, Pump	1
12	M22009	. Insert, Rotor	1
13	M8645	. Pump Body	1
14	*FHFP3-4C	. Screw (Pump Body to Motor)	2
15	69248	. Elbow, 90°	1
16	M22997	. Plug	1
17	M23105	. Screw, Pressure Adjustment	1
18	M10993-1	. Spring, Compression (Pressure Relief)	1
19	M8940	. Ball, 1/4 in. dia.	1
20	M25022-1	. Motor	1

AP Indicates attaching parts.

* Standard hardware. Purchase locally.

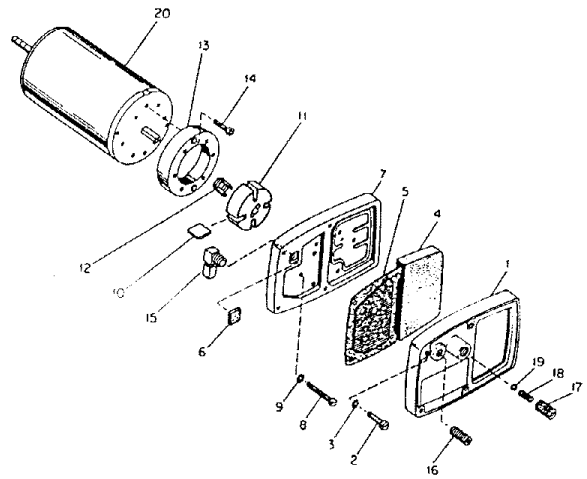

Figure 17. Motor Package Assembly

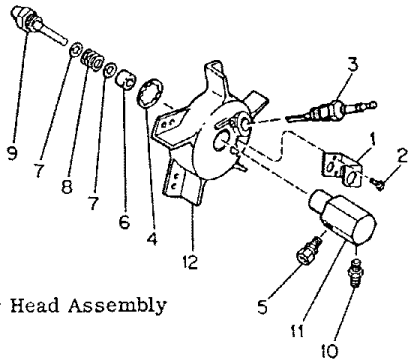

Figure 16. Burner Head Assembly

Index No.	Part Number	Part Name	Qty.
16-	M23443-2	Burner Head Assembly	Ref.
1	M16660	. Bracket, Photo Cell	1
2	*M10908-1	. Screw, Hex hd., Self- tapping, No. 6-32 x 1/4 (AP)	2
3	M10962-2	. Spark Plug	1
4	M16741-18	. Ring, Retaining	1
	M23151-2	. Nozzle Adapter Assembly	1
5	M5976	. . Connector, Male	1
6	M8882	. . Sleeve, Nozzle Seal	1
7	M10659-1	. . Washer, Nozzle Seal	2
8	M10809-1	. . Spring, Nozzle Seal	1
9	M13960	. . Nozzle, Aspirating	1
10	M16791	. . Connector, Male	1
11	M16535	. . Adapter, Nozzle	1
12	M25020	. Body, Burner Head	1

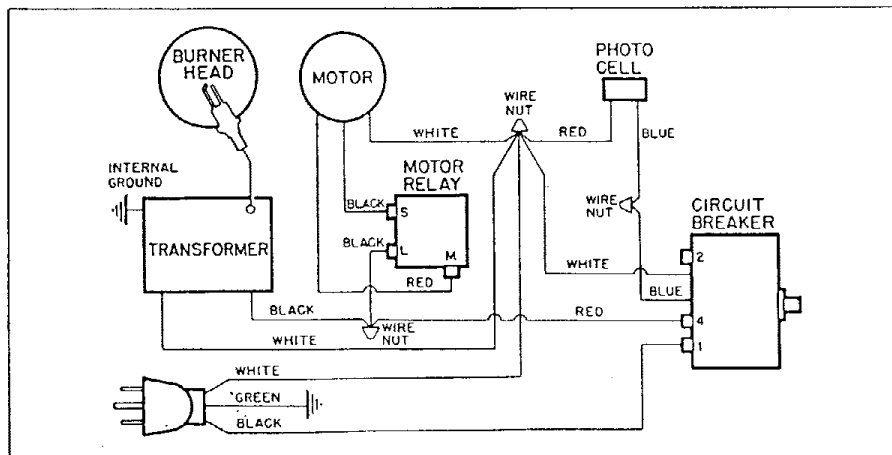
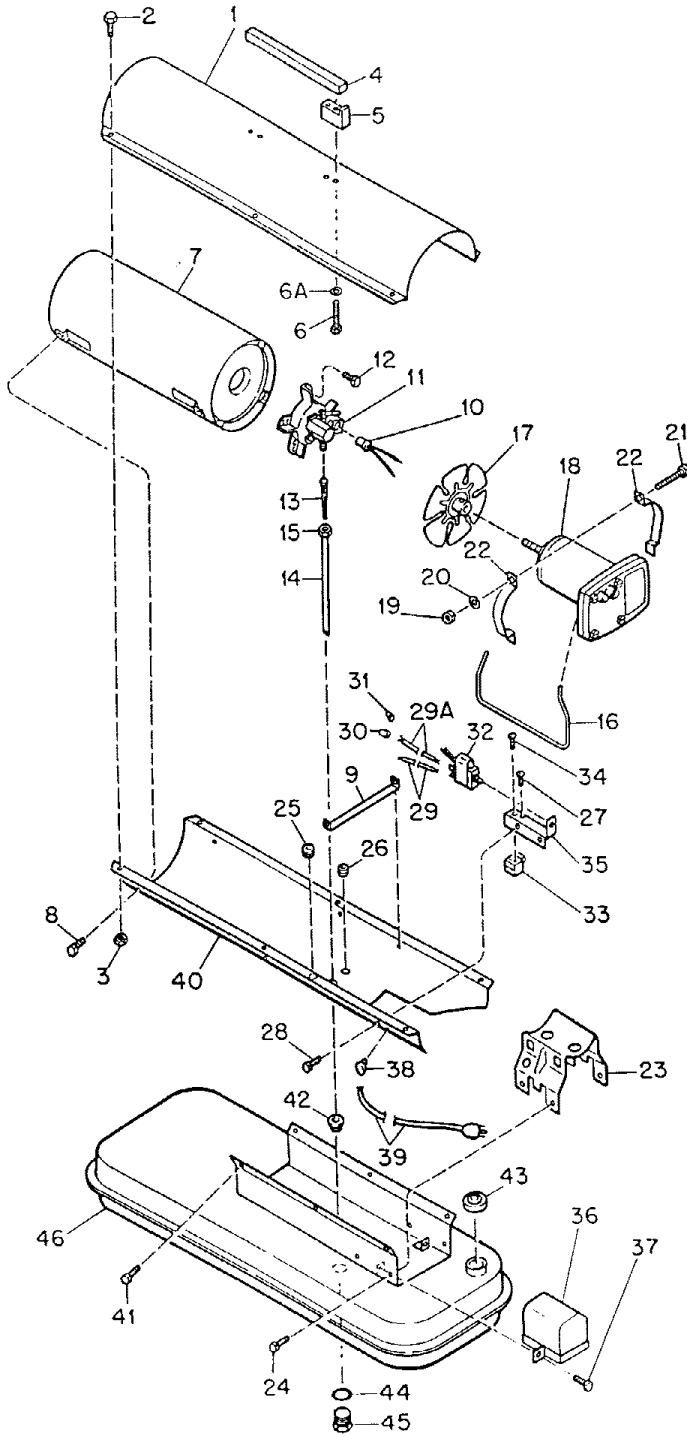

Figure 11. Wiring Diagram

QUEEN-B MODEL SB50S
 Spec. No. 3183G10
 Form No. 2960 (6/73)

PARTS LIST



Index No.	Part Number	Part Name	Qty.
1	M25030-2D	Shell, Upper	1
2	M12461-49	Screw, Hex hd., No. 10-24 x 1/4 (AP)	6
3	NPC-3C	Nut, Plain 10-24	6
4	M25278	Handle	1
5	M12439L	Support, Handle	2
6	M10908-58	Screw, Hex hd., No. 10-24 x 1-1/2 (AP)	4
6A	WP-4C	Washer, Plain No. 10 (AP)	4
7	M25019-1	Combustion Chamber Assy	1
8	M11084-26	Screw, Hex hd., Self-tapping No. 10-12 x 3/8 in. (AP)	4
9	M25645	Strap, retainer	1
10	M16656-3	Photo Cell and Bushing Assembly	1
11	M23443-2	Burner Head Assembly (For details see Fig. 16)	NA
12	M11084-27	Screw, Hex hd., self-tapping No. 10-12 x 1/2 in. (AP)	3
13	M19630	Filter, Fuel	1
14	M16790-14	Tube, Fuel filter	1
15	M13849	Nut, Flared	1
16	M25021	Air Line	1
17	M25727	Fan, 25/32 inch pitch	1
	SF4-2-1/2K	Setscrew, Socket hd, cup point, 1/4-28 x 5/16 (Furnished with fan)	2
18	M25023-1	Motor Package Assembly (For details see Fig. 17)	1
19	NPC-4C	Nut, Plain, Hex 1/4-20 (AP)	2
20	WLM-4	Lockwasher, 1/4 in. (AP)	2
21	HC4-10C	Screw, Hex hd., 1/4-20 x 1-1/4 in. (AP)	2
22	M16661	Clamp, Motor	4
23	M25059	Bracket, Motor Support	1
24	M11084-27	Screw, Hex hd., self-tapping, No. 10-12 x 1/2 in. (AP)	4
25	1000576	Grommet	2
26	1000577	Grommet	1
27	ST2-2AC	Screw, Rd. hd., No. 8-15 x 1/4 in. (Grounding)	1
28	M11084-26	Screw, Hex hd., self-tapping No. 10-12 x 3/8 in.	2
29	M16841-15	Wire Assembly	1
29A	M16841-16	Wire Assembly	1
30	M13942-2	Connector, Wire	2
31	M13942-4	Connector, Wire	1
32	M24982-5	Control Assembly, Safety	1
33	M25061-1	Relay, Motor start	1
34	M11084-26	Screw, Rd. hd., No. 10-12 x 3/8 in. (AP)	2
35	M25035	Bracket, Relay	1
36	M16697	Transformer Assembly	1
37	M11084-27	Screw, Hex hd., self-tapping No. 10-12 x 1/2 in.	2
38	M11143-1	Bushing, Strain relief	1
39	M10813-38	Extension Cord Assembly	1
40	M25031F	Lower Shell Assembly	1
41	M11084-26	Screw, Hex hd., self-tapping, No. 10-12 x 3/8 in. (AP)	4
42	M10990-3	Bushing	1
43	M23284	Cap, Filler Neck	1
	M25374-1	Plug Assembly, Drain	1
44	M25375	O-Ring	1
45	M25277	Plug, Drain	1
46	M26224-2F	Fuel Tank Assembly	1

Figure 15. Heater Exploded View