

Figure 14. Burner Head Assembly

Index No.	Part Number	Part Name	Qty
14-	M23443-3	Burner Head Assembly	Ref.
1	M16660	. Bracket, Photo Cell	1
2	*M10908-1	. Screw, Hex hd., Self-tapping, No. 6-32 x 1/4 (AP)	2
3	M10962-2	. Spark Plug	1
4	M16741-18	. Ring, Retaining	1
	M23151-4	. Nozzle Adapter Assembly	1
5	M5976	. Connector, Male	1
6	M8882	. Sleeve, Nozzle Seal	1
7	M10659-1	. Washer, Nozzle Seal	2
8	M10809-1	. Spring, Nozzle Seal	1
9	M26316	. Nozzle, Aspirating	1
10	M16791	. Connector, Male	1
11	M16535	. Adapter, Nozzle	1
12	M25020	. Body, Burner Head	1

Index No.	Part Number	Part Name	Qty.
15-	M25023-1	Motor Package Assembly (See figure 13)	Ref.
1	M16545	. End Cover, Filter	1
2	*M12461-31	. Screw, Hex hd. No. 10-32 x 1 (AP)	4
3	*WLI-3	. Lockwasher, Internal No. 10 (AP)	4
4	M12179	. Intake Air Filter	1
5	M12244-1	. Output Filter Assy	1
6	M11637	. Filter, Lint	1
7	M12233	. Front Cover, Pump (Port Plate)	1
8	*M12461-32	. Screw, Hex hd. No. 10-32 x 1-1/8 (AP)	6
9	WLI-3	. Lockwasher, Internal No. 10 (AP)	6
10	M8643	. Blade, Pump	4
11	M22456-1	. Rotor, Pump	1
12	M22009	. Insert, Rotor	1
13	M8645	. Pump Body	1
14	*FHFP3-4C	. Screw (Pump Body to Motor)	2
15	69248	. Elbow, 90°	1
16	M22997	. Plug	1
17	M23105	. Screw, Pressure Adjustment	1
18	M10993-1	. Spring, Compression (Pressure Relief)	1
19	M8940	. Ball, 1/4 in. dia.	1
20	M25022-1	. Motor	1

AP Indicates attaching parts.

* Standard hardware. Purchase locally.

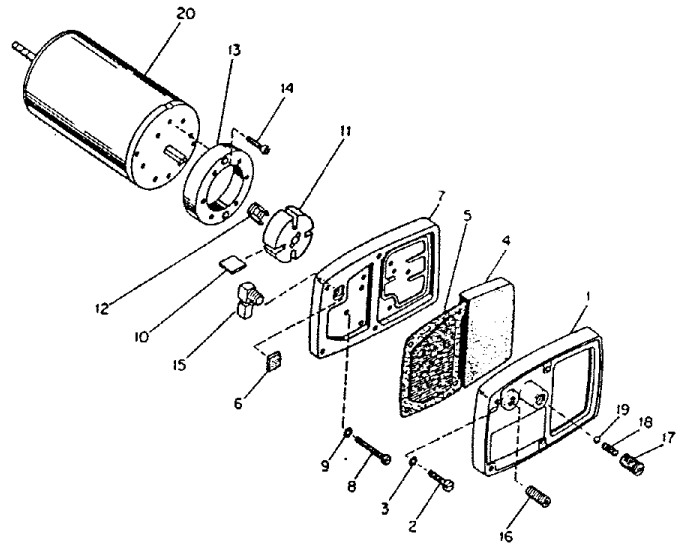
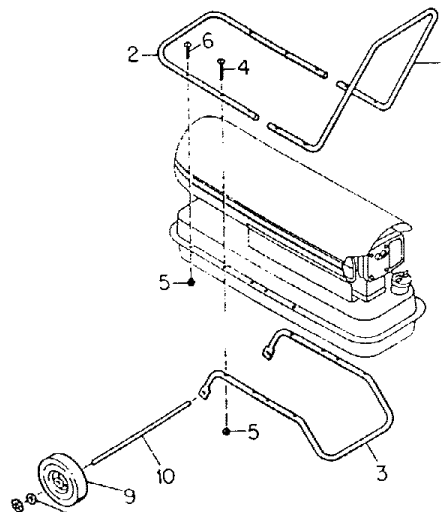

Figure 15. Motor Package Assembly

Fig. & Index No.	Part Number	Part Name	Qty.
16-1	M26287A	Handle, Rear	1
2	M26286A	Handle, Front	1
3	M26205B	Frame, Wheel Support	1
4	M12345-33*	Screw, Oval hd., 10-24 x 1-3/4 in.	8
5	NTC-3C*	Nut, Torque Lock No. 10-24	10
6	M12345-31	Screw, Oval hd., 10-24 x 1 in.	2
7	M16741-15	Ring, Retaining	2
8	WP-8C*	Washer, Flat, 1/2 inch	2



PARTS LIST

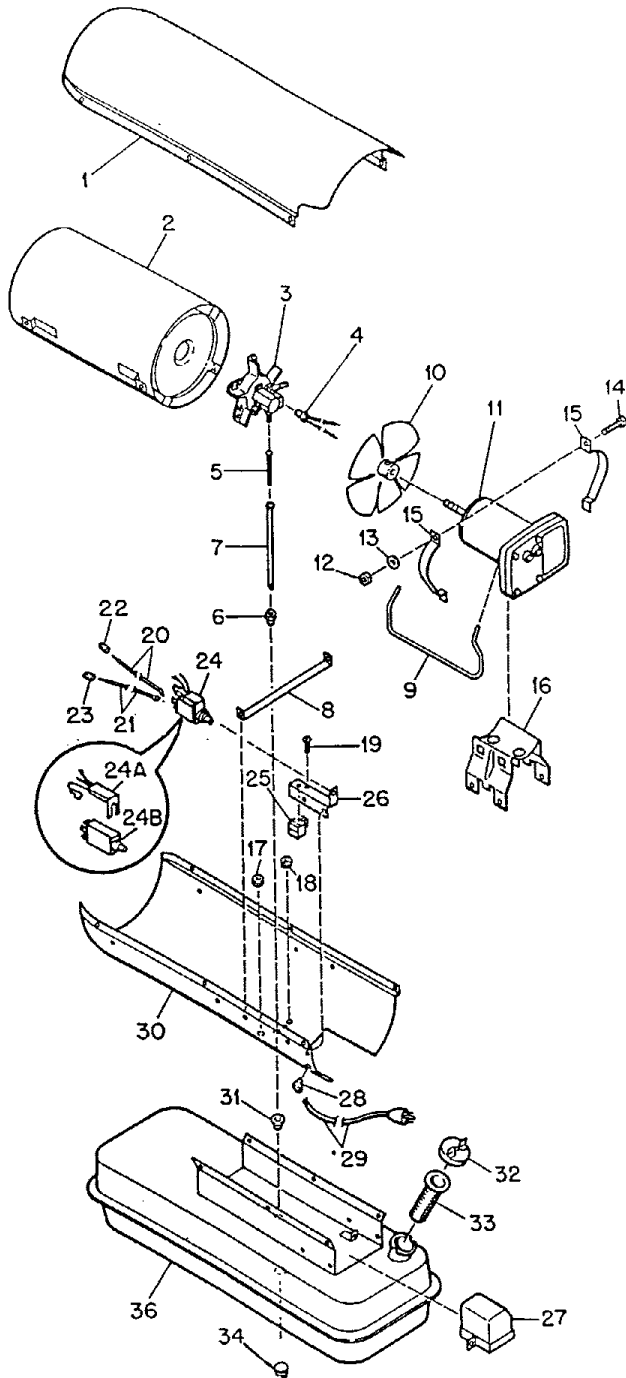

Figure 13. Heater Exploded View

Fig. & Index No.	Part Number	Part Name	Qty.
13-1	M26207C	Shell, Upper	1
-	M11084-26*	Screw, Hex hd., No. 10-12 x 3/8 in. (AP)	6
-	M11271-6*	Nut, Tinnerman	6
2	M25019-1	Combustion Chamber Assy	1
3	M23443-3	Burner Head Assembly (For details see Figure 14)	NA
4	M16656-3	Photocell and Bushing Assy	1
5	M19630	Filter, Fuel	1
6	M13849	Nut, Flared	1
7	M16790-14	Tube Fuel Filter	1
8	M25645	Strap, Retainer	1
9	M25021	Air Line	1
10	M25727	Fan, 25/32 pitch	1
-	SF4-2-1/2K*	Set screw, Socket Hd., cup pt., 1/4-28 x 5/16 (furnished with fan)	2
11	M25023-1	Motor Package Assembly (For details see Figure 15)	1
12	NPC-4*	Nut, Plain, Hex, 1/4-20 (AP)	2
13	WLM-4*	Lockwasher, 1/4 in. (AP)	2
14	HC4-10C*	Screw, Hex hd., 1/4-20 x 1-1/4 in. (AP)	2
15	M16661	Clamp, Motor	2
16	M25059	Bracket, Support	1
-	M11084-27*	Screw, Hex hd., No. 10-12 x 1/2 in. (AP)	4
17	1000576	Grommet	2
18	1000577	Grommet	2
19	ST2-2AC*	Screw, Rd. hd., No. 8-15 x 1/4 in. (Grounding)	1
-	M11084-26*	Screw, Hex hd., No. 10-12 x 3/8 in. (Relay Bracket)	2
20	M16841-15	Wire Assembly	2
21	M16841-16	Wire Assembly	2
22	M13942-2	Connector, Wire	2
23	M13942-4	Connector, Wire	2
24	M24982-5	Safety Control Assy	1
25	M25061-1	Relay, Motor Start	1
-	RC2-2C*	Screw, Rd. hd., 8-32 x 1/4 in. (AP)	2
26	M25035	Bracket, Relay	1
27	M25024-1	Transformer Assembly	1
-	M11084-27*	Screw, Hex hd., 10-12 x 1/2 in. (AP)	2
28	M11143-1	Bushing, Strain Relief	1
29	M10813-38	Extension Cord Assembly	1
30	M26208C	Lower Shell Assembly	1
-	M11084-26*	Screw, Hex hd., 10-12 x 3/8 in. (AP)	6
31	M10990-3	Bushing	1
32	M23284	Cap, Filler Neck	1
33	M18053	Screen, Filler Neck	1
-	M25374-1	Drain Plug Assembly	1
34	M25375	O-Ring	1
35	M25277	Plug, Drain	1
36	M26224-1B	Fuel Tank Assembly	1

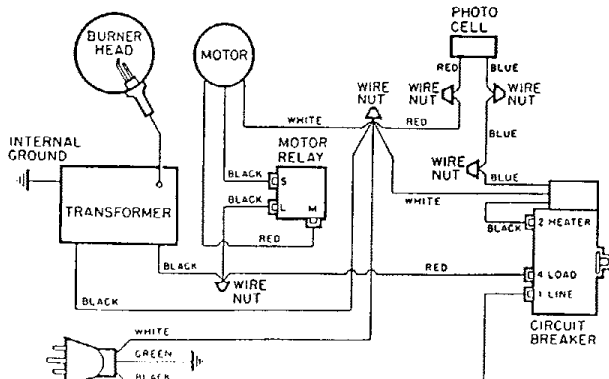

Figure 9. Wiring Diagram